



Robotunits Cobot Station

The Robotunits Cobot Station allows quick and easy installation of your collaborative robot.

Facts:

- 100% solution from the Robotunits modular system
- customized
- proven application

Applications such as machine operation, assembly, gluing applications or simple pick & place tasks can be quickly handled.

There is sufficient space in the substructure to accommodate the most common Cobot controllers. These are also easily accessible via the door. Application-specific components (such as holders for teach pendants, workpiece holders, tools, etc.) can be mounted to the open t-slots of the work surface. Push buttons or sensors can be subsequently mounted by the operator.

Advantages for the customer:

- lead time is 4 weeks from date of order
- can be adapted to on-site conditions
- compatible for a wide range of cobots

Via lifting rollers with integrated locking feet, the substructure is mobile and can be stably positioned for operation.

Any questions?

Our sales team will be happy to inform you about further possibilities and develop your individual solution in collaboration with you.

<https://robotunits.com/contact>

Not included in the delivery: Cobot, controls and wiring

Robotunits Cobot Station

Technical data

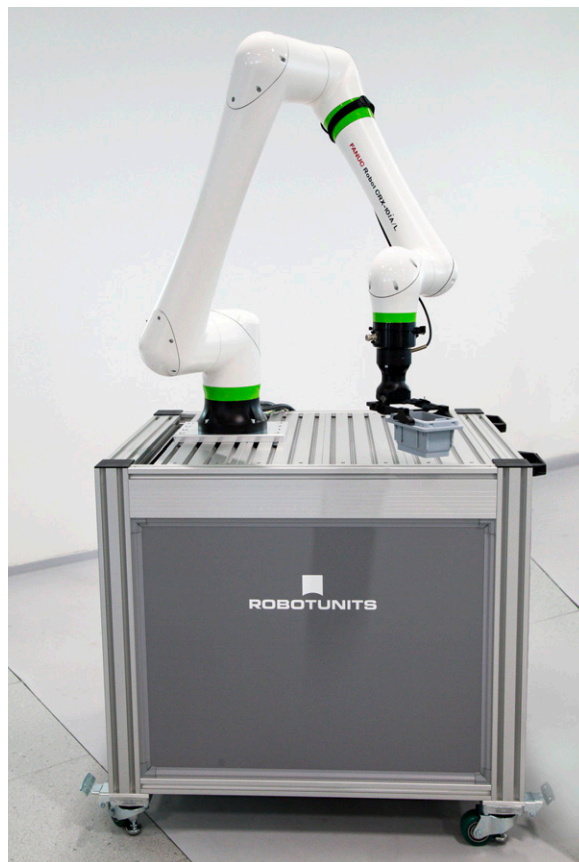

Substructure	Unit	Value
min. width	[mm]	800
min. length	[mm]	1000
max. top surface height	[mm]	1000
min. weight	[kg]	70

Robot	Unit	Value
max. range	[mm]	1400
TCP speed	[mm/s]	500
max. handling weight	[kg]	10
max. dead weight of robot	[kg]	40

Controls
Recommendation:
install in the substructure

Compatible with:

ABB
CRB 14050 (YuMi)
CRB 15000 (GoFa)
IRB/CRB 1100
(SWIFTI)

Fanuc
CR-4iA
CRX-5iA
CR-7iA and
CR-7iA/L
CRX-10iA
CRX-10iA/L

UR
UR3e
UR5e
UR10e

If the parameters of the station or the cobot are exceeded, the station must be fixed to the ground to prevent it from tipping over. The mounting position of the robot must be placed in the center.

Robotunits Cobot Station

Dimensions

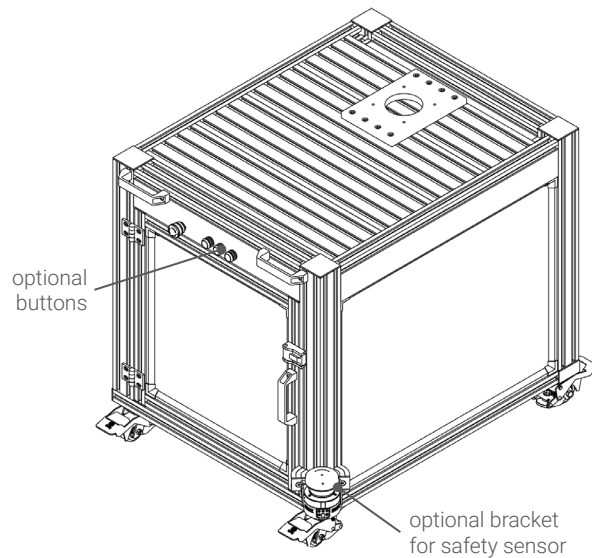
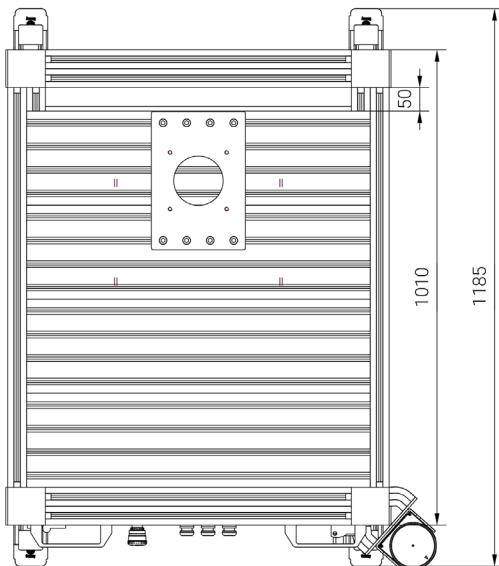
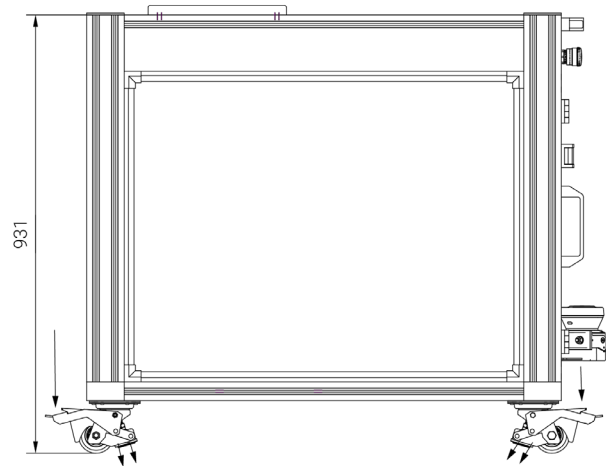
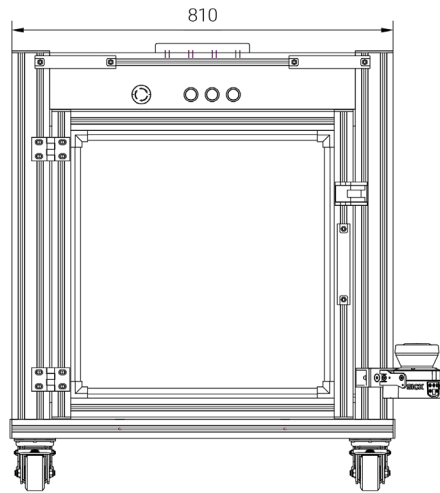

Robotunits GmbH
Dr. Walter Zumtobel Str. 2
6850 Dornbirn
Austria

Tel. +43 5572 22000 200
info.usa1@robotunits.com
robotunits.com

**The simplest, fastest and most flexible
Modular Automation System in the world**

More with less. The Modular Automation System from Robotunits offers a maximum of possibilities with a minimum of components. Thanks to the high degree of standardization, all elements of the Modular Automation System can be easily combined. Play-free and vibration-proof, without drilling and milling. Decades of project experience and personal customer service guarantee time and cost savings for our customers.