

Linear Motion

Installation instructions

Index

1.	Allgemeines	3	
1.1.	Hersteller der Anlage	3	
1.2.	Einleitung / Zweck der Montageanleitung	3	
1.3.	Geforderte Voraussetzungen/Bedingungen,	3	
1.4.	Version	3	
2.	Sicherheit	4	
2.1.	Allgemeines	4	
2.2.	Vernünftiger Weise vorhersehbare Fehlanwendung	4	
3.	Transport	5	
3.1.	Lager-/Transportbedingungen unvollständigen Maschine		5
3.2.	Anforderungen Transportmittel	5	
4.	Inbetriebnahme	6	
4.1.	Einstellen der Riemenspannung	6	
4.2.	Einstellen der Trumkraft	6	
4.3.	Einstellung des Schlittens	7	
5.	Wartung	9	
5.1.	Anforderungen Wartungspersonal	9	
5.2.	Wartungstabelle	9	
5.3.	Instandsetzungsarbeiten	9	
5.4.	Riemenwechsel	9	
6.	Mechanischer Aufbau	11	
6.1.	Linearachse Aufbau	11	
6.2.	Linearachsen System	12	

1. General

1.1. Manufacturer of the system

Robotunits GmbH
Dr. Walter Zumtobel Str. 2
A-6850 Dornbirn
Tel. +43 5572 22000 200
www.robotunits.com

1.2. Introduction / purpose of the operating manual / installation instructions

Linear axes that are delivered without drive/control are considered an incomplete machine (Machinery Directive 2006/42/EC, Art. 2g), and this document is accordingly considered a set of installation instructions.

Please see the enclosed documents for the required installation declaration.

1.3. Required preconditions / conditions at the site

the installation site for installing the incomplete machinery:

- Sufficient load capacity to accommodate the linear drive (weight can be taken from technical data sheet)
- Plane surfaces on the flange positions
- Bores for the screw connections
- Installation position (according to technical data sheet)
- Where required, coverings for drives and movement area of the guide carriage
- Movement limitation by sensors or stop (if sensors)
- Electrical connection values and connection type (according to technical data sheet)

1.4. Version

Version	Art	Datum
4	Installation instructions	12/01/2021

2. Safety

2.1. General

The security of the operator and trouble-free operation of the incomplete machine is only guaranteed with the use of original machine parts.

2.2. Reasonably foreseeable misuse



The incomplete machine is not designed for operation at environmental temperatures outside -20 to $+60$ °C. In relation to the atmospheric moisture, the limit values of protection class IP54 are to be observed.

The use of the incomplete machine in explosive atmospheres is prohibited.

3. Transport / assembly

3.1. Storage / transport conditions of incomplete machinery



During transport and storage, the incomplete machinery must be secured against tipping over. Movable parts (e.g. carriages) must be fixed in position. Do not store the incomplete machine outdoors.

3.2. Requirements for transport materials



When lifting consider the center of gravity of the machine. Do not stand under the load.



Be sure to use adequate packaging and transport materials.

4. Operating instructions

4.1. Adjusting the belt tension

The belt tension must be readjusted after the first 1000 movements!
As a matter of principle, it is important to always tighten both screws of the belt tensioning set uniformly so that the belt is tensioned in parallel.

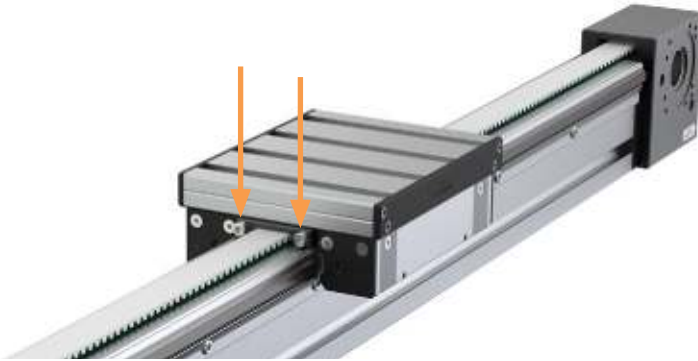

4.2. Adjusting the span force

The tension force is a function of: belt effective length, belt width, specific own weight and resonant frequency. Tension force or resonant frequency can be determined with a tension meter.

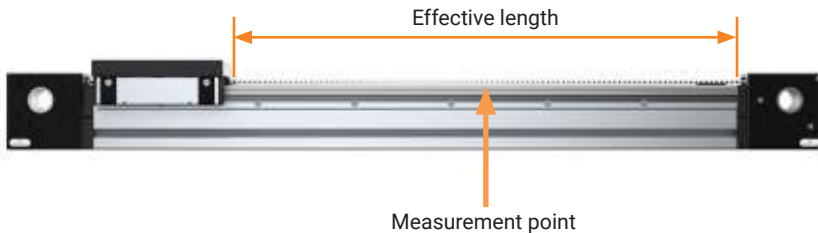

The resonant frequency for Robotunits linear motion units can be calculated as follows.

$$T = \frac{M}{r} * 1,1$$

$$f = \frac{1}{2 * L} * \sqrt{\frac{T}{W}}$$

T = Belt tension (N)
M = Torque (Nm)
r = Effective radius = 0.0318 m

f = Resonant frequency (Hz)
L = Effective length (m)
W = Specific own weight
Belt = 0.155 kg/m

4. Operating instructions

4.3. Adjusting the carriage

Due to tolerance and variable types of load, the carriage play must be readjusted after the first 1000 movements.

Attention: The slides can only be adjusted without a belt mounted on the slide!

Procedure:

4.3.1. Loosen the grub screw to unlock the jam nut



4.3.2. Use the Allen key to let the eccentric roller line up on the guide rail without expenditure of force.



4. Operating instructions

4.3.3. Take out any play between carriage and guide rail.

4.3.4. Fix the eccentric roller by tightening the jam nut with the corresponding wrench.



4.3.5. Fix the set screw to secure the excenter nut

4.3.6. Check the carriage for smooth running. The carriage must be moved with a force of 18 – 20 N.

Attention: Adjust without a belt mounted on the slide!



5. Maintenance

Proper machine maintenance is essential for reliable operation and long life. Any maintenance may only be carried out after the incomplete machine has been disconnected from the power supply.

5.1. Requirements for maintenance personnel

Any maintenance is to be carried out by suitably qualified and authorized personnel.

5.2. Maintenance table

Service point / activity	Maintenance interval	Info
Belt tension	After 1000 operating cycles	Once
Slide play	After 1000 operating cycles	Once
Clean linear guide	Every 600 h	
ALubricate wiper unit	Every 600 h	Slideway oil DIN CGLP ISO VG68 (e. g. Mobil Vactra No. 2)
Check belt condition	Every 600 h	Visual
Check machine for loosened screws	Every 2000 h	

5.3. Repair work

Repairs may only be carried out by Robotunits or by a service center authorized by Robotunits.

5.4. Belt change

5.4.1. Loosen the screws of the belt tensioning set:



5. Wartung

5.4.2. Entfernen des Riemenspannteiles:



5.4.3. Befestigungsschrauben einer Umlenkungen lösen:



5.4.4. Riemen ausziehen:



6. Mechanischer Aufbau

6.1. Linearachse Aufbau

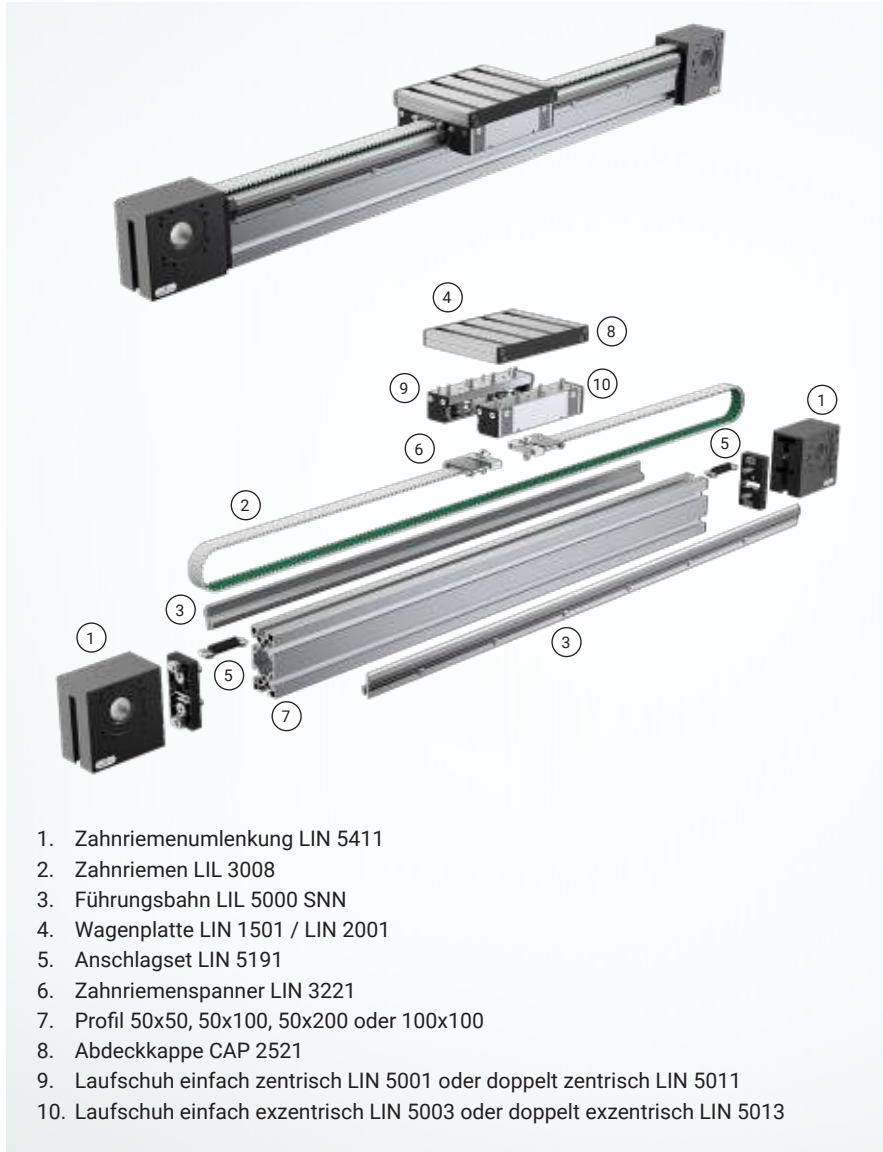

6. Mechanischer Aufbau

6.2. Linearachsen System





Wir behalten uns vor, technische Änderungen jederzeit durchzuführen.
Für Satz- und Druckfehler übernehmen wir keine Haftung.

Österreich • Deutschland • Schweiz • Italien • Frankreich • Spanien • Tschechien • USA • Australien

www.robotunits.com