



Diverter without cover plate



Diverter with cover plate

Application

Sorting of conveyed goods with various sizes. Can be integrated into any conveyor line

Technical data

Brushless 24 V DC motor for rotary motion and rollers (2 motorized rollers per conveyor line)
 Temperature range from + 2°C to + 40°C
 Max. continuous current per motorized roller: 2.5 A
 Turning range: - 90° to + 90°
 Housing material: coated steel
 Roller material: PU
 Max. weight of conveyed material: 35 kg
 Max. throughput: 6,000 products per hour
 Max. roller speed: 90 m/min

Supported control protocols:

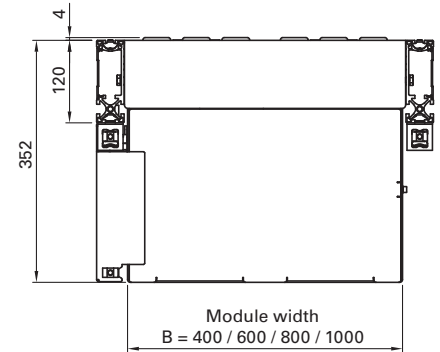
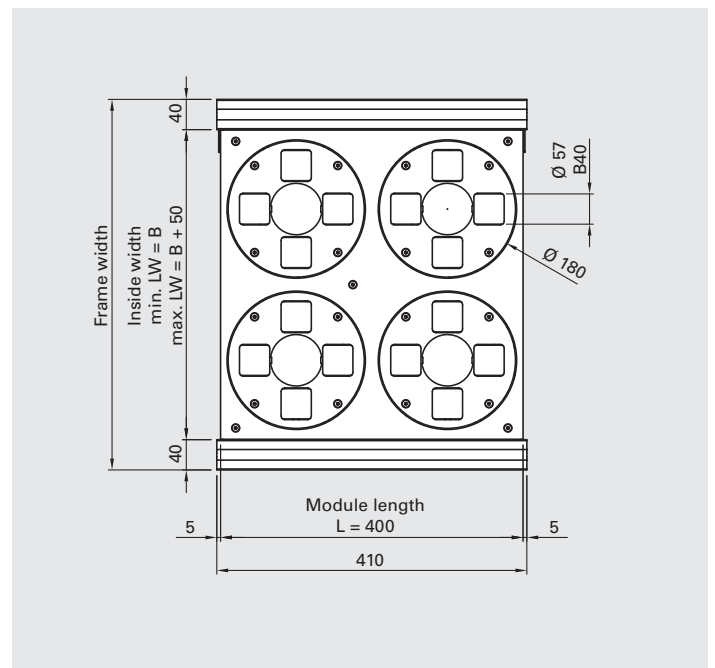
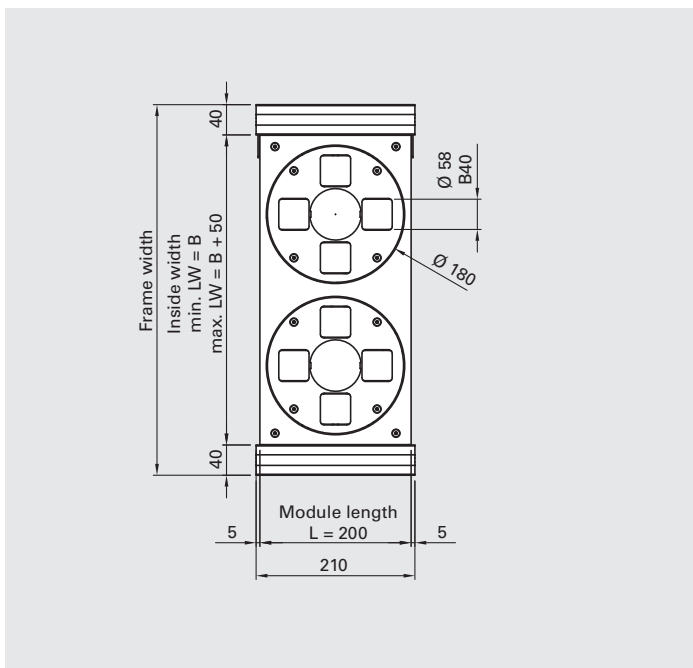
**Single Line Diverter****Double Line Diverter****Request/Order**

The selection of the appropriate diverter depends on the product, dimensions, weight, throughput, conveying speed and angle of ejection. For more information, visit www.robotunits.com or contact us.

Drawings: dimensions in mm