

Extrusion Tolerances

Straightness

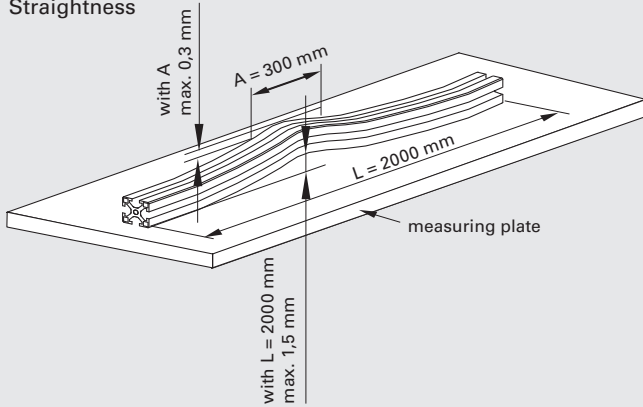

Torsion

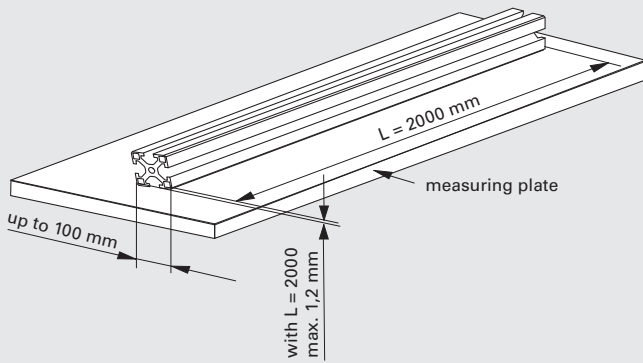

Parallelism

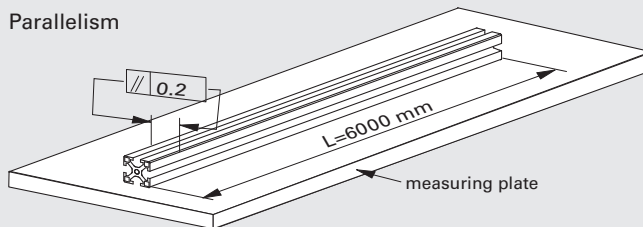

Technical data – extrusions:

Material description:	EN AW-6063 - T66
Minimum tensile strength R_m (in direction of pressure):	245 N/mm ²
Yield strength R_p (in direction of pressure):	200 N/mm ²
Modulus of elasticity E:	70000 N/mm ²
Shear Modulus G:	26000 N/mm ²
Coefficient of linear expansion:	$\alpha = 23 \cdot 10^{-6} 1/K$
Brinell hardness:	approx. 70 HB
Breaking elongation A5:	12%
Material density:	2.7 kg/dm ³
Cutting data:	
Length tolerance (up to 6000 mm):	± 0.2 mm
Rectangular accuracy:	up to 50 mm ± 0.05 mm up to 100 mm ± 0.1 mm up to 200 mm ± 0.2 mm
Tolerances for precision extrusions:	DIN EN 12020-2
Groove tolerance:	14 $+0.25 / -0$ mm

E	[N/mm ²]	Modulus of elasticity
F	[N]	Load
F_G	[N]	Net weight
f	[mm]	Deflection
L	[mm]	Length
I	[cm ⁴]	Moment of inertia (see extrusion data sheets)
W	[cm ³]	Section modulus (see extrusion data sheets)
$\sigma_{max.}$	[N/mm ²]	Permissible bending stress (recommendation 70 N/mm ²)
M_t	[Nmm]	Torque
I_t	[cm ⁴]	Torsional moment of area
G	[26000 N/mm ²]	Shear Modulus
φ	[°]	Rotation angle

Deflection Calculations

Load case example 1

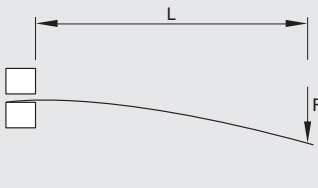

Deflection by force F

$$f = \frac{F \cdot L^3}{3 \cdot E \cdot I \cdot 10^4} \text{ [mm]}$$

Deflection under own weight

$$f = \frac{F_G \cdot L^3}{8 \cdot E \cdot I \cdot 10^4} \text{ [mm]}$$

Bending stress σ max.

$$\sigma = \frac{F \cdot L}{W \cdot 10^3} \text{ [N/mm}^2\text{]}$$

Load case example 2

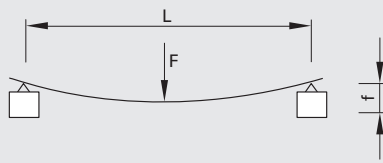

$$f = \frac{F \cdot L^3}{48 \cdot E \cdot I \cdot 10^4} \text{ [mm]}$$

Deflection under own weight

$$f = \frac{5 \cdot F_G \cdot L^3}{384 \cdot E \cdot I \cdot 10^4} \text{ [mm]}$$

Bending stress σ max.

$$\sigma = \frac{F \cdot L}{4 \cdot W \cdot 10^3} \text{ [N/mm}^2\text{]}$$

Load case example 3

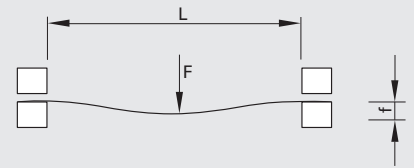

$$f = \frac{F \cdot L^3}{192 \cdot E \cdot I \cdot 10^4} \text{ [mm]}$$

Deflection under own weight

$$f = \frac{F_G \cdot L^3}{384 \cdot E \cdot I \cdot 10^4} \text{ [mm]}$$

Bending stress σ max.

$$\sigma = \frac{F \cdot L}{8 \cdot W \cdot 10^3} \text{ [N/mm}^2\text{]}$$

Torsion Calculations

Load case example 1

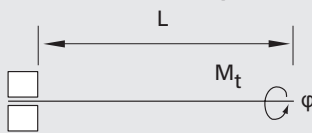

$$\Phi = \frac{180^\circ \cdot M_t \cdot L}{\pi \cdot G \cdot I_t \cdot 10^4} \text{ [mm]}$$

Load case example 2

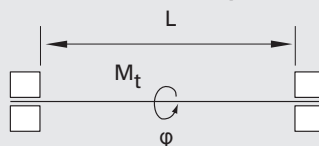

$$\Phi = \frac{180^\circ \cdot M_t \cdot L}{\pi \cdot 4 \cdot G \cdot I_t \cdot 10^4} \text{ [mm]}$$

Checking the shear stress

The critical factor for failure of an extrusion subject to torsional load is in practice not so much the exceeding of the maximum approved torsional load applied to the extrusion, but rather elastic deformation (torsion). This deformation will affect the functioning of any parts to be assembled onto the extrusion, and so a more torsion-resistant extrusion must be selected, well before the approved maximum values for the torsional load have been reached.

Standard Screw Drawing

Code	Screw designation	ISO standard	DIN standard
IBS M_x__	Socket-head cap screw	ISO 4762	DIN 912
IBS M_x__NIKO	Socket-head cap screw with flat head		DIN 6912
SKS M_x__	Socket-head countersunk screw	ISO 10642	DIN 7991
LKS M_x__	Button head cap screw with socket head	ISO 7380	
HKS M_x__	Hexagon head screw	ISO 4017	DIN 933
SKM M__	Hexagonal nut	ISO 4032	DIN 934
SKM M__FLA	Hexagonal nut, flat form	ISO 4035	DIN 936
BLS M__	Washer	ISO 7089	DIN 125
BLS M__S__	Washer		DIN 7349
GST M_x__	Set screw with socket head and conical cup	ISO 4026	DIN 913
GST M_x__SPI	Set screw with socket head and tip	ISO 4027	DIN 914
GST M_x__FED	Spring-loaded pressure part with band and hexagonal socket head		
BKS_x__	Countersunk flat head tapping screw	ISO 7050	DIN 7982
PAF_x_x__	Key	ISO 773	DIN 6885
PKS_x__	Grooved pin	ISO 8745	DIN 1472
SIR_x__	Circlip		DIN 471
SPS_x__	Clamping pin, lightweight	ISO 13337	DIN 7346