



***THE VERSATILE
MBS PICKSTAR***



Modern factories are geared towards high speed production. Time pressure increases constantly. Changeover time between production runs need to be shorter. Therefore product cycles and demanding customers require a new dimension in flexibility.

The solution is now available: Robotunits expands its Modular Automation System with a unique concept for material handling. Only 8 multifunctional components allow for a large range of applications.



Individual lengths and widths

- Lane length and width can be easily adjusted
- No tools needed to change lane width
- Additional tracks can be added if load requires



Adjustable angle

- Infinitely adjustable angle
- Track can be attached to the tube clamp in the front, or in the T-slot of the extrusion
- Brakes can be inserted anywhere on the track to control the speed of the box



Safe and rigid design

- Rigid system through Robotunits Fastening Technology
- Tight fitting track covers prevent contamination of roller tracks
- Low noise level due to special gliding bearings
- Entire construction available for ESD
- Anti-Reverse can be placed anywhere on the track
- Colored anti-reverse shows maximum fill level



High Flexibility

- Open T-slots can be used to install additional components
- Tracks can be inserted in any of the Robotunits extrusions
- Quick assembly without special tools
- System can be easily adjusted for new requirements



System compatible

- All components fully compatible with the Robotunits Modular Automation System
- Multifunctional stop elements allow safe in-feed and removal of material
- Unlimited applications due to 14 mm T-slot
- Reduced inventory cost due to multifunctional parts



Save time, reduce cost

- Minimal design effort necessary
- Snap-in connections for quick assembly
- Minimal training required
- Individual adjustments possible



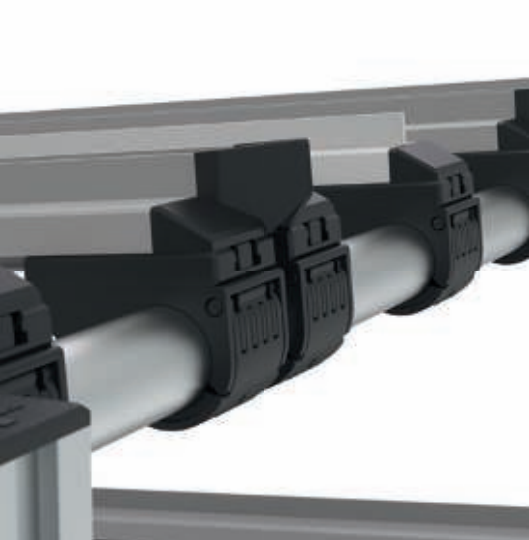

The versatile MBS PickStar

MBS PickStar Overview

Page 118



MBS PickStar Rolling

Page 120

<p>RollerTrack MA_456_  P. 122</p>	<p>RollerTrack With Side Guides MA_459_  P. 123</p>	<p>Tube Clamp Front MAT 30_1  P. 124</p>	<p>Front Part MAT 455_  P. 125</p>	<p>Brake for RollerTrack MAT 4580  P. 126</p>
<p>Anti-Reverse For RollerTrack MAT 4575  P. 127</p>	<p>RoundTube 30x2 PIL 3002  P. 134</p>	<p>Cover for Round Tube 30x2 CAP 3002  P. 134</p>	<p>Label Holder 50 x 100 MAT 3050  P. 135</p>	

MBS PickStar Sliding

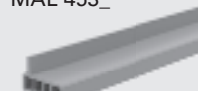
Page 128

<p>Sliding Rail MAL 453_  P. 130</p>	<p>Tube Adapter MAT 303_  P. 131</p>	<p>Extrusion Adapter MAT 403_  P. 132</p>	<p>Adapter MAT 903_  P. 133</p>	<p>RoundTube 30x2 PIL 3002  P. 134</p>
<p>Cover for Round Tube 30x2 CAP 3002  P. 134</p>	<p>Label Holder 50x100 MAT 3050  P. 135</p>			



MBS PickStar Rolling

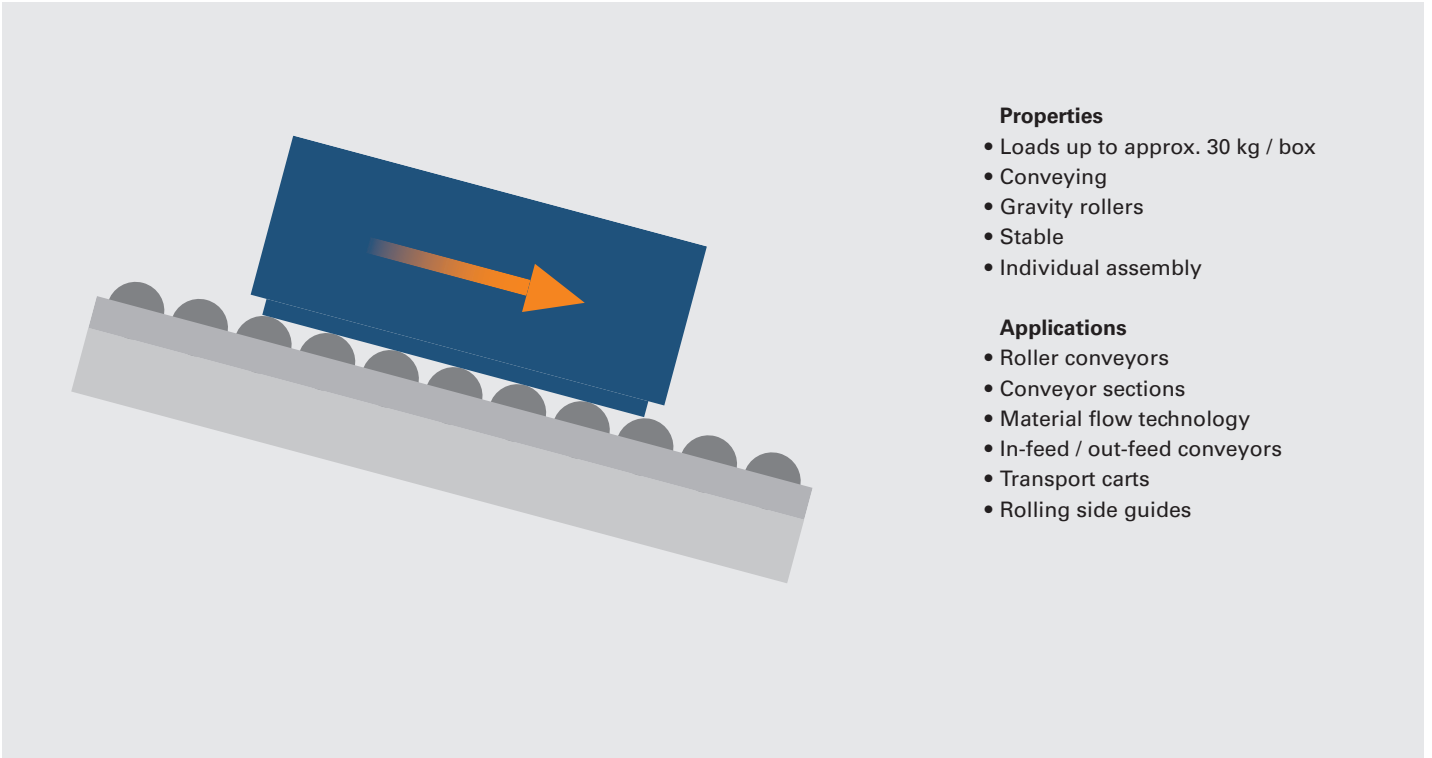

Properties

- Loads up to approx. 30 kg / box
- Conveying
- Gravity rollers
- Stable
- Individual assembly

Applications

- Roller conveyors
- Conveyor sections
- Material flow technology
- In-feed / out-feed conveyors
- Transport carts
- Rolling side guides

Compact System Options



Ergonomic System Options



MBS PickStar Sliding

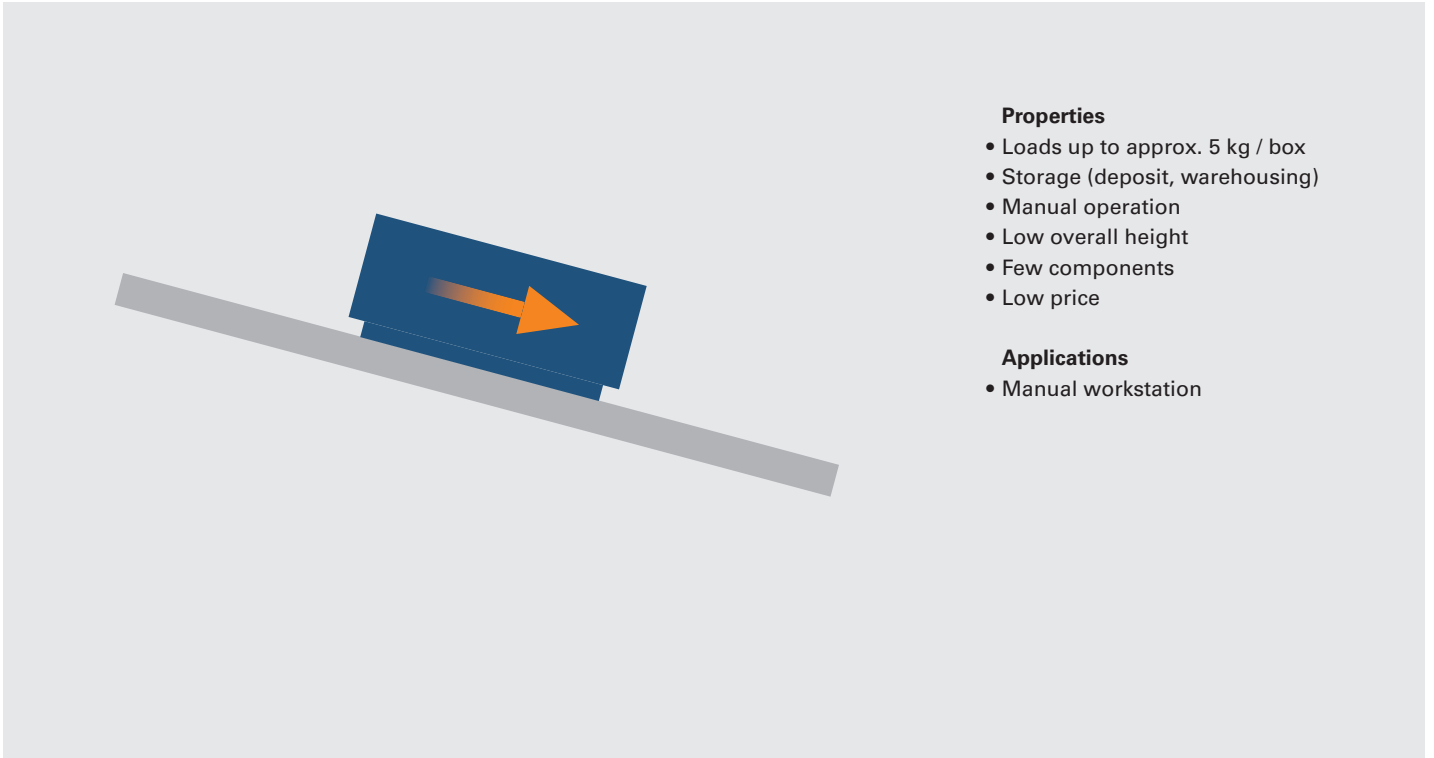

Round System Options



Square System Options



MBS PickStar Rolling - Compact



Benefits

- Flexible track width, inside height
- Lower overall height
- Few components

Application

- KANBAN carts, workstations

Freely combinable system options

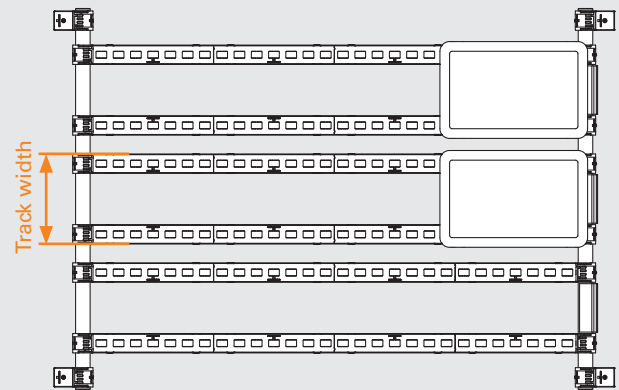
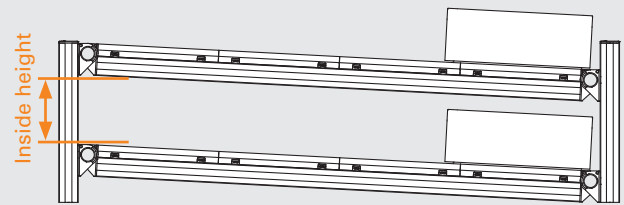

Design MBS PickStar Rolling - Compact

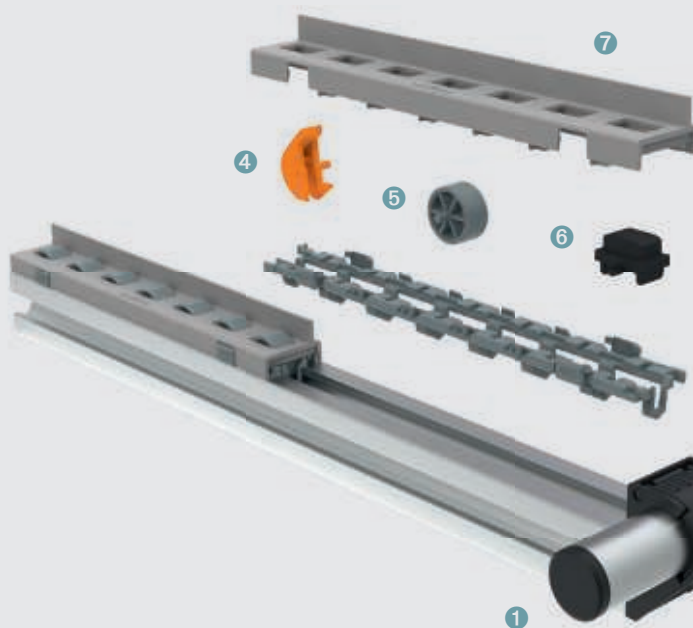

- 1 Round Tube 30x2 PIL3002 (page 134)
- 2 Tube Clamp ESD Front Kit MAT3011 (page 124)
- 3 Label Holder MAT3050 (page 135)
- 4 Anti-Reverse For RollerTrack MAT 4575 (page 127)
- 5 Roller for RollerTrack
- 6 Brake for RollerTrack MAT4580 (as of page 126)
- 7 RollerTrack With Side Guides MAT4591 (as of page 123)

MBS PickStar Rolling - Ergonomic



Benefits

- Flexible adjustable inclination, track width, protrusion, inside height
- Staggered configuration
- Individual arrangement

Application

- Ergonomic (semi-circular) gripping chamber application

Freely combinable system options

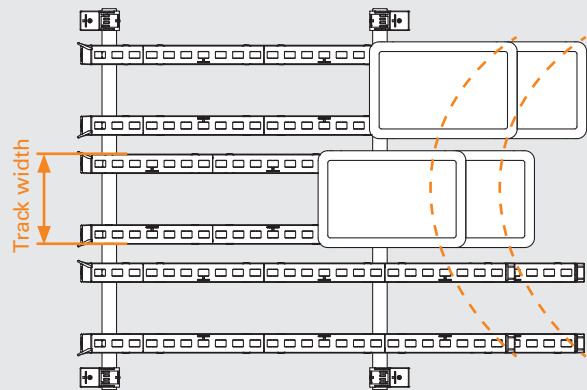
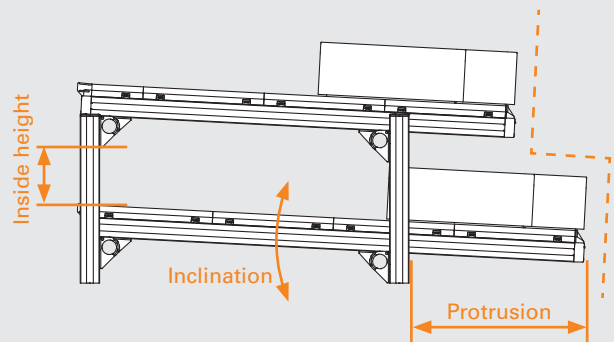

Design MBS PickStar Rolling - Ergonomic

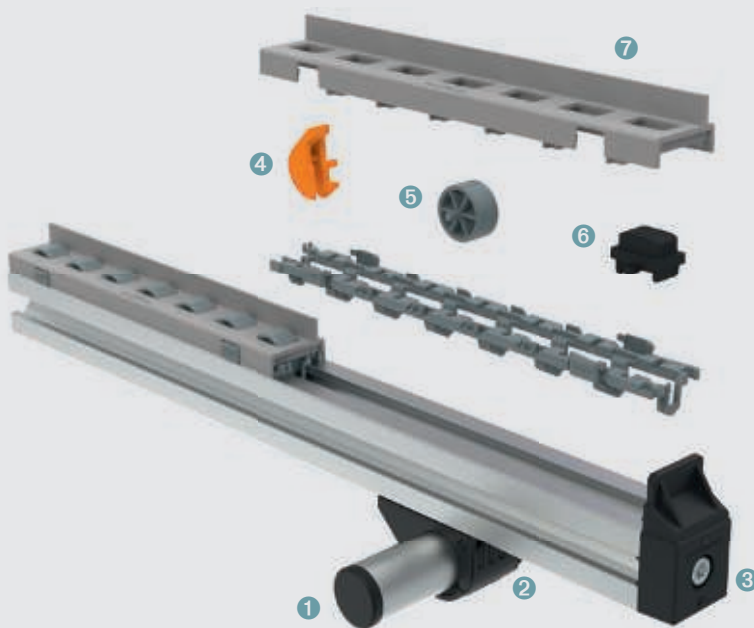

- 1 RoundTube 30x2 PIL3002 (page 134)
- 2 Tube Adapter ESD Kit (page 131)
- 3 Front Part ESD Stop Kit (page 125)
- 4 Anti-Reverse For RollerTrack MAT 4575 (page 127)
- 5 Roller for RollerTrack
- 6 Brake for RollerTrack MAT4580 (as of page 126)
- 7 RollerTrack With Side Guides MAT4591 (as of page 123)

MAT 4561



MAT 4563



Application

For roller conveyors, e.g. for:

- Material flow technology
- Manual workstations
- In- and out-feed conveyors
- Transport carts
- Rolling side guides

Technical Data

Material: Base part and gray PP or black PP cover (ESD conductive)
Roller gray POM-C or black POM-C (ESD conductive)

Max. load per unit 15 kg

Inclination angle (depending on the product to be transported)

MAT 4561: 4° to 5°

MAT 4563: 5° to 6°

Surface resistance per Roller Track
 $R_s < 35 \text{ M}\Omega$

ESD Conductivity

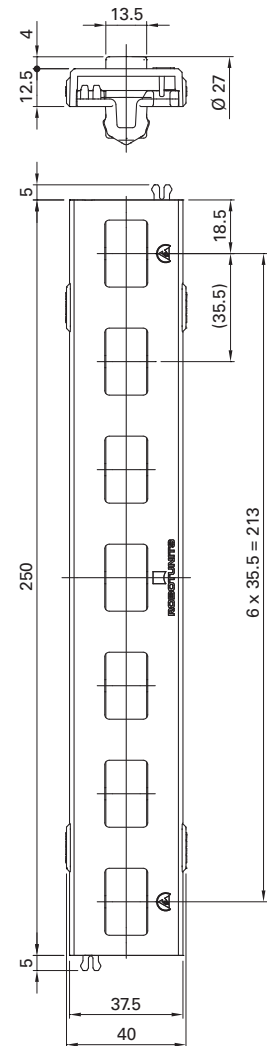
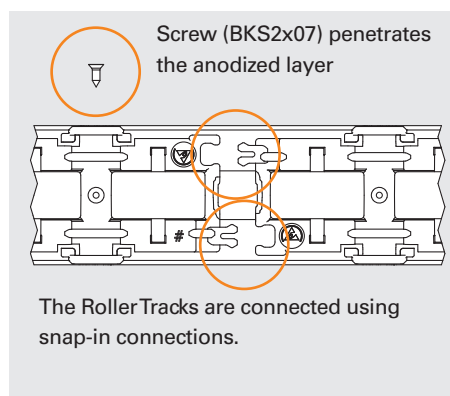

Order Code

Description	Scope of Delivery				Order Code ¹	Weight
	Base Part	Cover	Castors	BKS2x07		
RollerTrack Kit	1	1	7	-	MAT 4561	0.112 kg
RollerTrack Kit, cut to length	1	1	X ²	-	MAL 4561 SNN ___ ³	0.448 kg/m
RollerTrack ESD Kit	1	1	7	1	MAT 4563	0.114 kg
RollerTrack ESD Kit, cut to length	1	1	X ²	1	MAL 4563 SNN ___ ³	0.456 kg/m

1) Please complete the order code by adding the desired length.

2) Number of rollers depending on the length of the cut-to-length RollerTrack

3) Ideal pre-cut lengths in the roller series (35.5 mm)

Drawing dimensions in mm

MAT 4591



MAT 4593



Application

For roller conveyors, e.g. for:

- Material flow technology
- Manual workstations
- In- and out-feed conveyors
- Transport carts

Technical Data

Material: Base part and gray PP or black PP cover (ESD conductive)

Roller gray POM-C or black POM-C (ESD conductive)

Max. load per unit 15 kg

Inclination angle (depending on the product to be transported)

MAT 4591: 4° to 5°

MAT 4593: 5° to 6°

Surface resistance per Roller Track
 $R_s < 35 \text{ M}\Omega$

ESD Conductivity

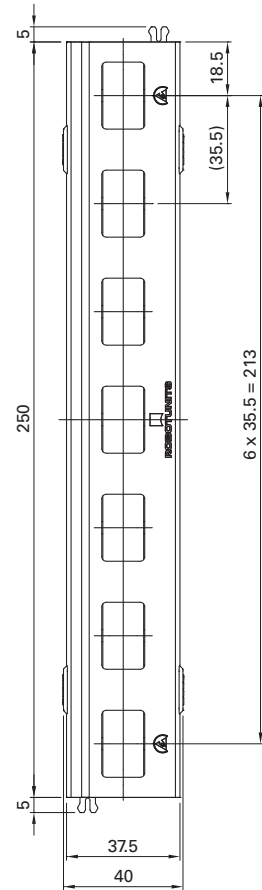
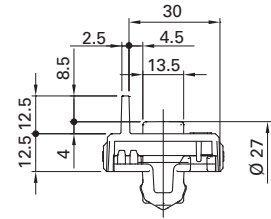
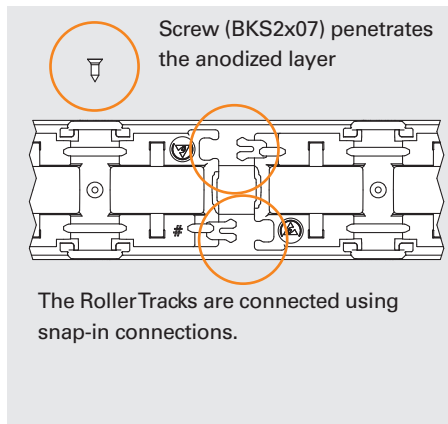

Order Code

Description	Scope of Delivery				Order Code ¹	Weight
	Base Part	Cover	Castors	BKS2x07		
RollerTrack With Side Guide Kit	1	1	7	-	MAT 4591	0.122 kg
RollerTrack With Side Guide Kit, cut-to-length	1	1	X ²	-	MAL 4591 SNN ___ ³	0.488 kg/m
RollerTrack ESD With Side Guide Kit	1	1	7	1	MAT 4593	0.124 kg
RollerTrack ESD With Side Guide Kit, cut-to-length	1	1	X ²	1	MAL 4593 SNN ___ ³	0.496 kg/m

- 1) Please complete the order code by adding the desired length.
 - 2) Number of rollers depending on the length of the cut-to-length RollerTrack
 - 3) Ideal pre-cut lengths in the roller series (35.5 mm)
- Drawing dimensions in mm

**Application**

Connector for fastening the Round Tube to the face or T-slot of the extrusion; Clamp can be opened without tools

Technical Data

Material: Base Part PA6, black (ESD conductive) Clamping Part PA6, black (ESD conductive) and TPV rubber, black
Fastening material: galvanized steel

Surface resistance per Tube Clamp
 $R_s < 35 \text{ M}\Omega$

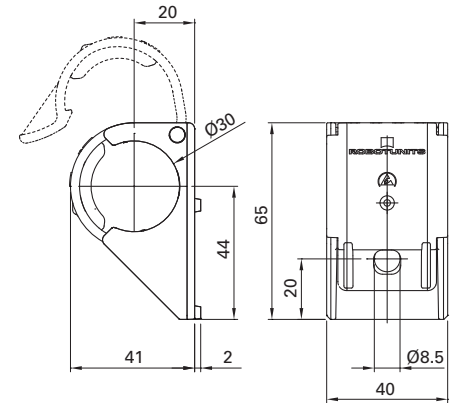
**ESD Conductivity**

Screw (BKS2x07) penetrates the anodized layer

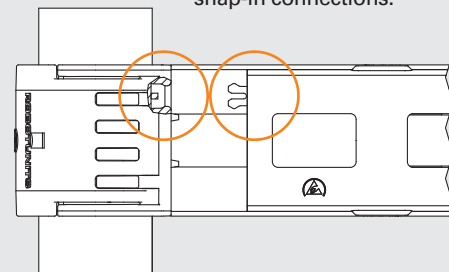

The Roller Tracks are connected using snap-in connections.

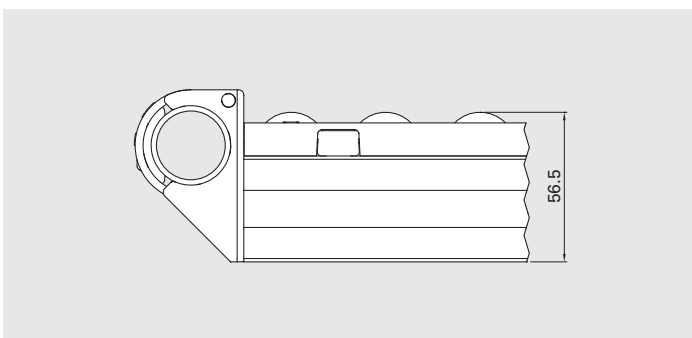
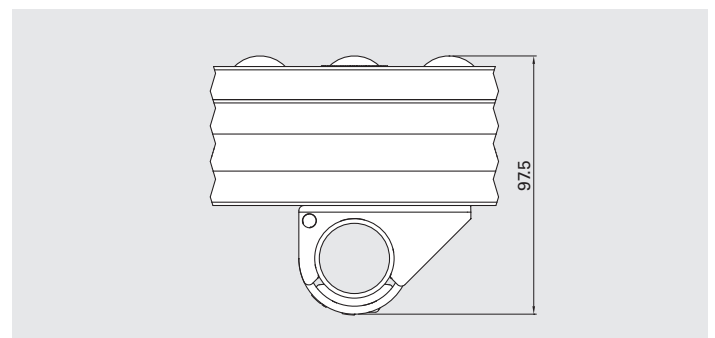
Compact Installed Height**Ergonomic Installed Height****Order Code**

Description	Scope of Delivery						Order Code	Weight
	Base Part	Clamping Part	IBS M08x018NIKO	BLS M008S02	BKS 2x07	TIN4598		
Tube Clamp ESD Front Kit	1	1	1	1	1	-	MAT 3011	0.052 kg
Tube Clamp ESD T-Slot Kit	1	1	1	1	1	1	MAT 3021	0.062 kg

Drawing dimensions in mm

MAT 455_

Front Part

MAT 4553

Stop Insert



IBS M08x025



Base Part

Application

Material stop at the start or the end of the RollerTrack
In-feed, removal or transfer support in combination with RollerTrack Without Side Guides

Technical Data

Material: PA6, black (ESD conductive)
Fastening material: galvanized steel

Surface resistance per Front Part
 $R_s < 35 M\Omega$

MAT 4553

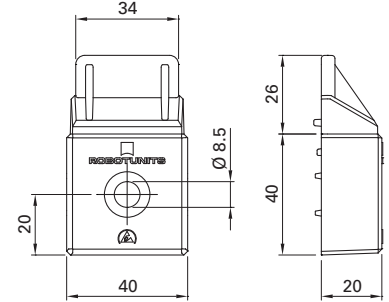

MAT 4555

Flat Insert

IBS M08x025



Base Part

ESD Conductivity

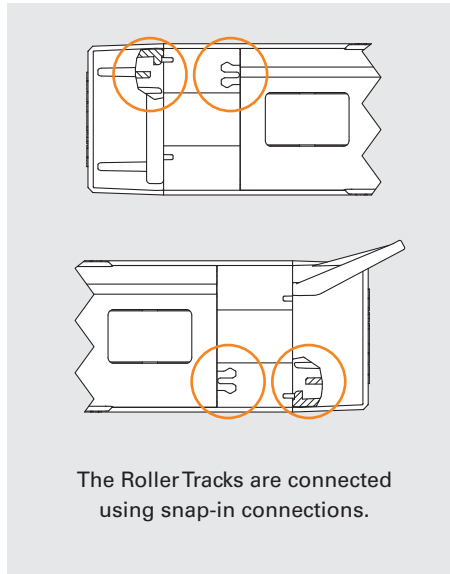

MAT 4555

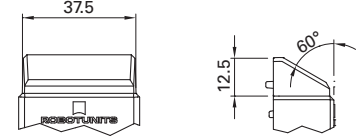

MAT 4557

Left Insert

IBS M08x025



Base Part

MAT 4557

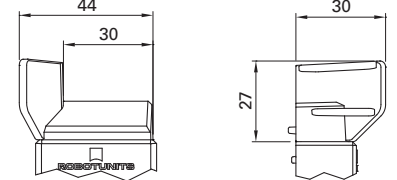

MAT 4559

Right Insert

IBS M08x025



Base Part

MAT 4559

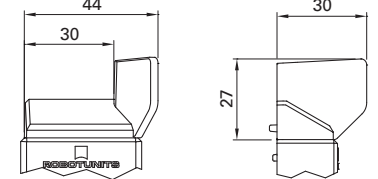

Variable Inserts

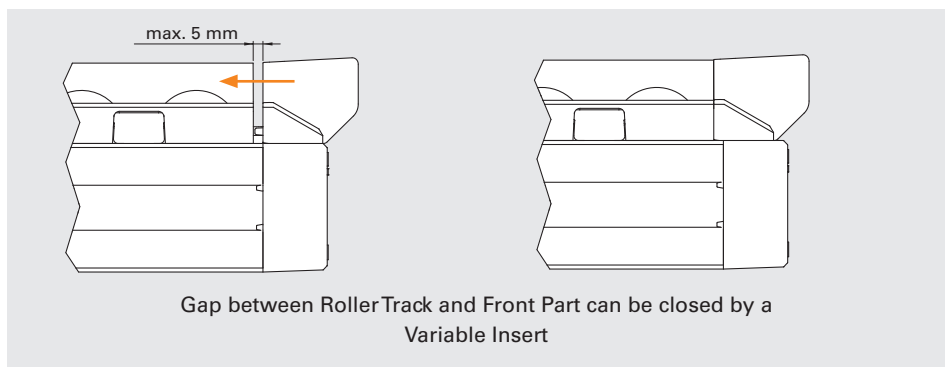

Order Code

Description	Scope of Delivery			Order Code	Weight
	Base Part	Insert	IBS M08x025		
Front Part ESD Stop Kit	1	1 (stop)	1	MAT 4553	0.036 kg
Front Part ESD Flat Kit	1	1 (flat)	1	MAT 4555	0.034 kg
Front Part ESD left Kit	1	1 (left)	1	MAT 4557	0.035 kg
Front Part ESD Right Kit	1	1 (right)	1	MAT 4559	0.035 kg

Drawing dimensions in mm

**Application**

Slowing down the transported product

Technical Data

Material: TPV rubber, black

Easy retrofitting possible.
(Switch Roller with Brake)
Depending on the product (weight,
condition of bottom, etc.) several
Brakes can be installed

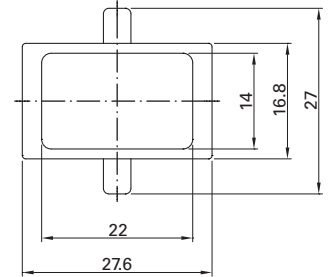
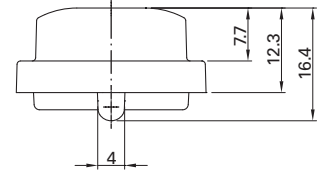
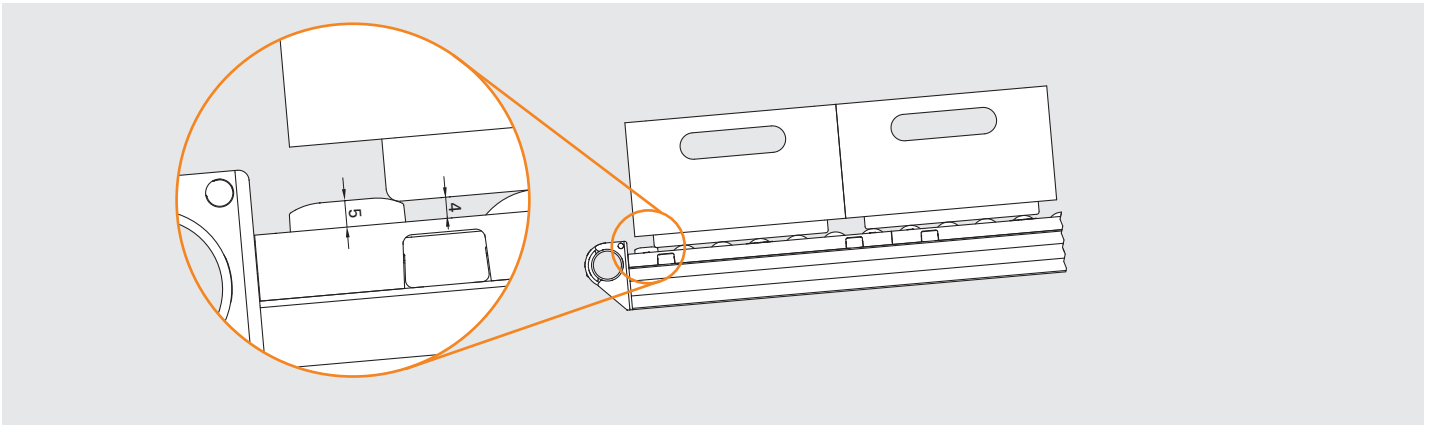
**Function****Order Code**

Description	Order Code	Weight
Brake For RollerTrack	MAT 4580	0.003 kg

Drawing dimensions in mm

MAT 4575

Anti-Reverse For Roller Track

**Application**

Material stop at the start or end of the RollerTrack

Prevents product at the back of the shelf from sliding down when product at the front is removed

Fill level indicator through signal color (visible = empty)

Technical Data

Material: POM-C orange

Easy retrofitting possible.
(Switch Roller with Anti-Reverse for RollerTrack)

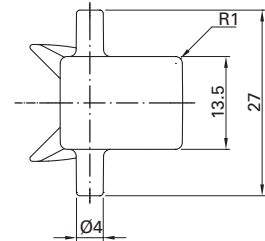
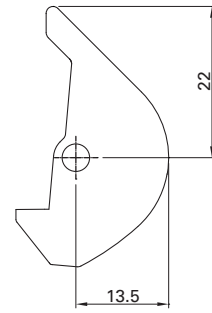

Function

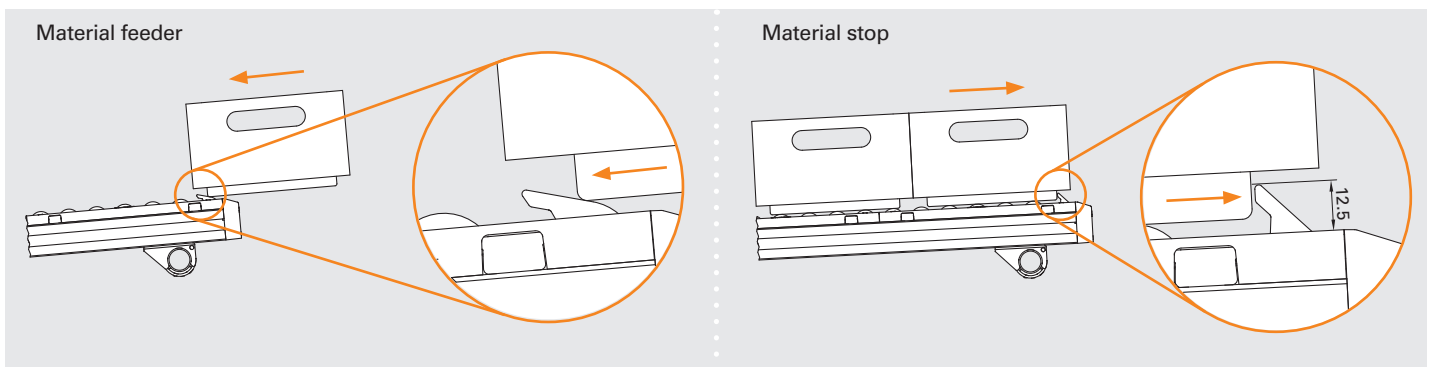

Order Code

Description	Order Code	Weight
Anti-Reverse For RollerTrack Kit	MAT 4575	0.006 kg

Drawing dimensions in mm

MBS PickStar Sliding - Round



Benefits

- Flexible adjustable track width
- Simpler assembly
- Freely adjustable incline

Application

Workstation with short tracks

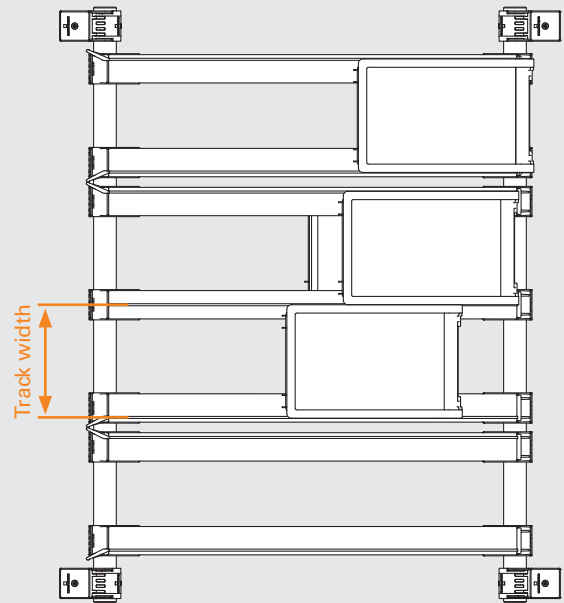
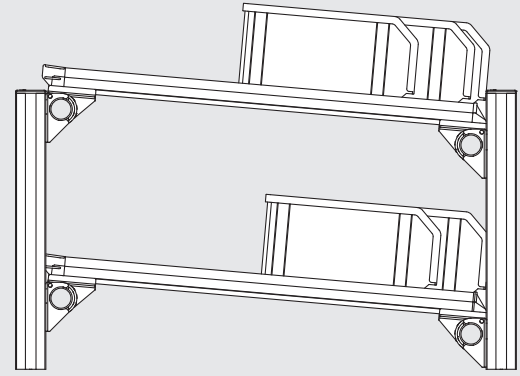

Design MBS PickStar Sliding - Round

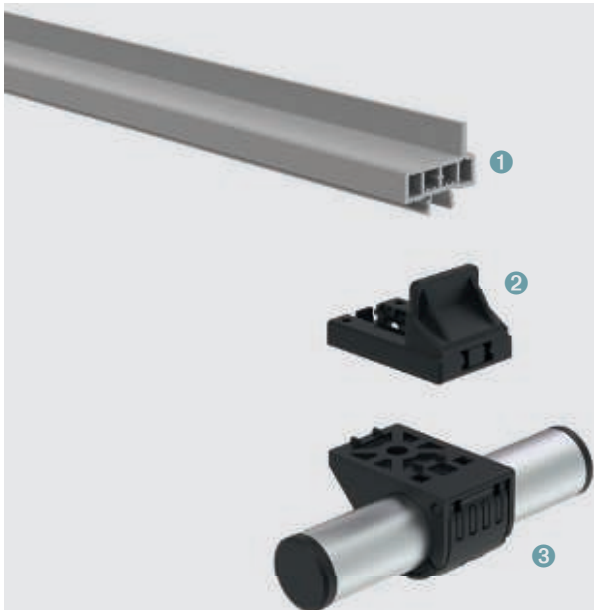

① Sliding Rail With Side Guide MAL4532 (page 130)

② Tube Adapter ESD Stop Kit MAT3033 (page 131)

③ Round Tube 30x2 PIL3002 (page 134)

MBS PickStar Sliding - Square

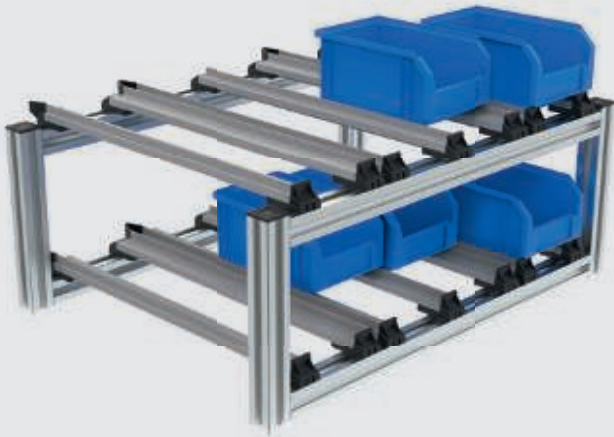

Benefits

- Sturdy frame design
- Greater width
- Subsequent installation directly onto extrusions

Application

Integration into existing extrusion frame

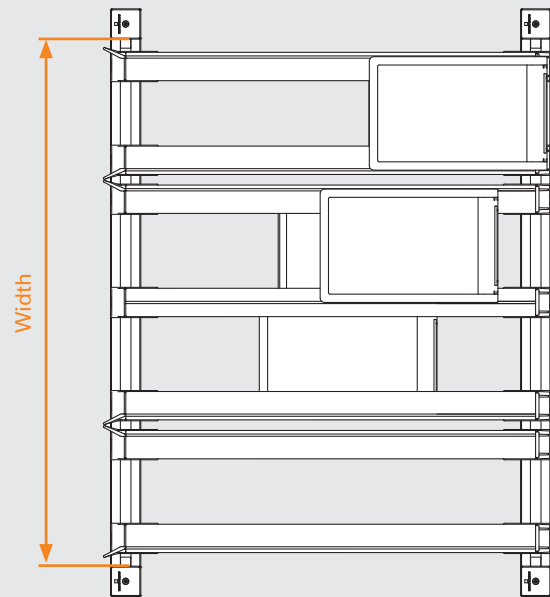
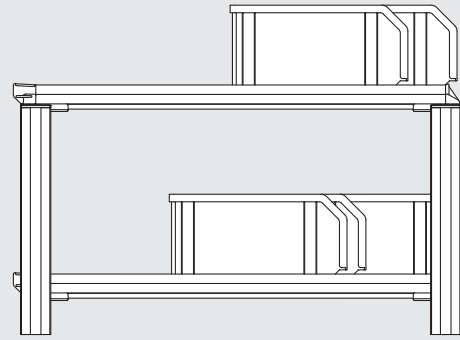

Design MBS PickStar Sliding - Square

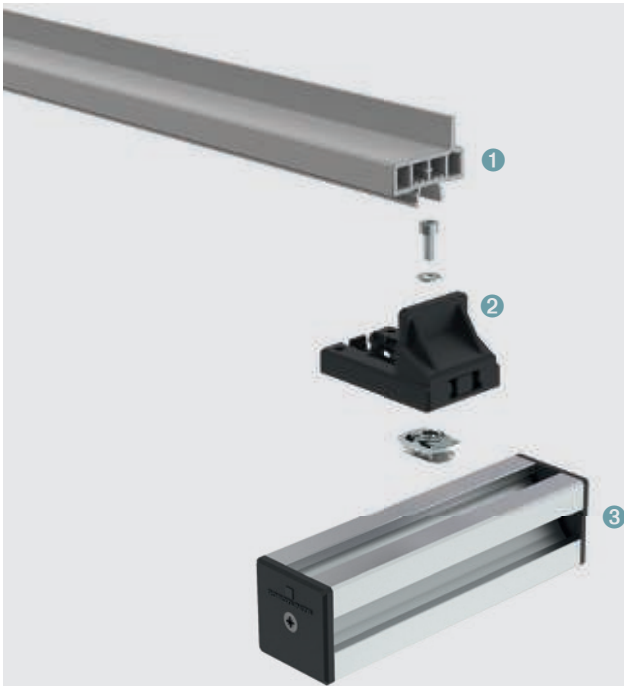

- 1 Sliding Rail With Side Guide MAL4532 (page 130)
- 2 Extrusion Adapter ESD Stop Kit MAT4033 (page 132)
- 3 Extrusion Technology (page 68)

MAL 4530



MAL 4532



MAL 4534



Application

For sliding tracks, e.g. for:

- Manual workstations

Technical Data of Sliding Rail (MAL 4530)

Material: gray PVC-U (antistatic)
 Modulus of elasticity E: 3000 N/mm²
 Section modulus W_x : 0.5 cm³
 Section modulus W_y : 1.6 cm³
 Area moment of inertia I_x : 0.6 cm⁴
 Area moment of inertia I_y : 2.9 cm⁴
 Load m: 1.5 kg

Technical Data of Sliding Rail With Side Guide (MAL 4532)

Material: gray PVC-U (antistatic)
 Modulus of elasticity E: 3000 N/mm²
 Section modulus W_x : 0.7 cm³
 Section modulus W_y : 1.7 cm³
 Area moment of inertia I_x : 1.2 cm⁴
 Area moment of inertia I_y : 3.4 cm⁴
 Load m: 2.5 kg

Technical Data of Sliding Rail With Center Guide (MAL 4534)

Material: gray PVC-U (antistatic)
 Modulus of elasticity E: 3000 N/mm²
 Section modulus W_x : 0.7 cm³
 Section modulus W_y : 1.6 cm³
 Area moment of inertia I_x : 1.2 cm⁴
 Area moment of inertia I_y : 2.9 cm⁴
 Load m: 2.5 kg

Surface resistance per sliding rail
 $R_s < 100 \text{ G}\Omega$

MAL 4530

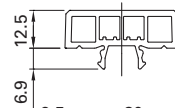

MAL 4532

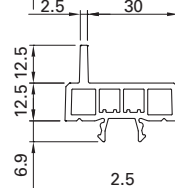

MAL 4534

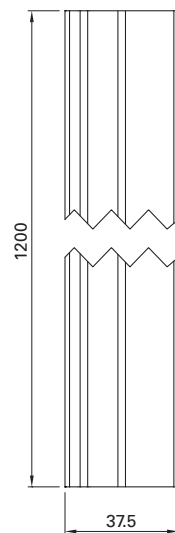
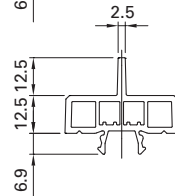

Load

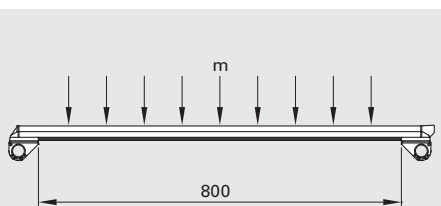

m = Maximum load per 800 mm of sliding rail

Application

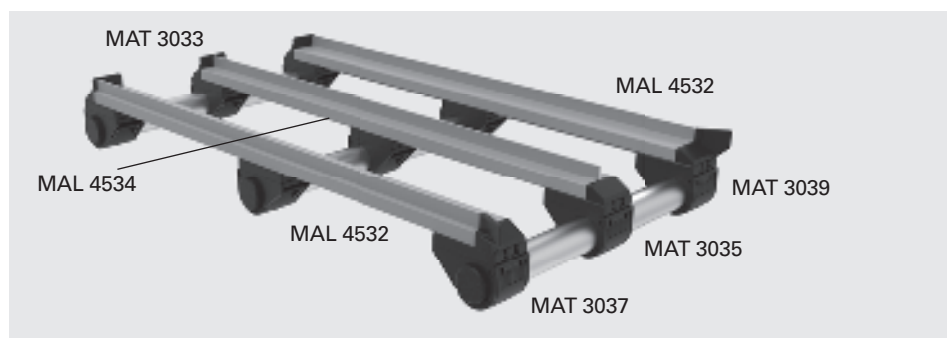

Order Code

Description	Order Code ¹	
	Length	Weight/Meter
Sliding Rail, cut to length	MAL 4530 SNN ____	0.290 kg
Sliding Rail, stock length 1200 mm	MAL 4530 NNN 1200	0.290 kg
Sliding Rail With Side Guide, cut to length	MAL 4532 SNN ____	0.330 kg
Sliding Rail With Side Guide, stock length 1200 mm	MAL 4532 NNN 1200	0.330 kg
Sliding Rail With Center Guide, cut to length	MAL 4534 SNN ____	0.330 kg
Sliding Rail With Center Guide, stock length 1200 mm	MAL 4534 NNN 1200	0.330 kg

1) Please complete the order code by adding the desired length.
 Drawing dimensions in mm

MAT 303_

Tube Adapter

MAT 3031



Application

Adapter to connect the Round Tube to the Sliding Rail

Technical Data

Material: Base part and adapter plate PA6, black (ESD conductive)
 Clamping Part PA6, black (ESD conductive) and TPV rubber black
 Inserts: PA6, black (ESD conductive)
 Conductivity screw: galvanized steel

Surface resistance per Tube Adapter
 $R_s < 35 M\Omega$

ESD Conductivity

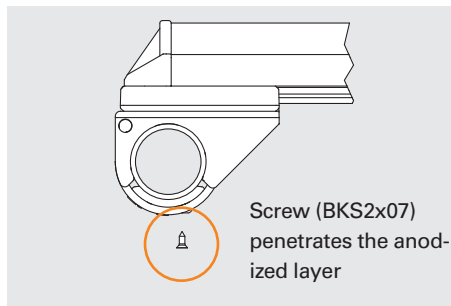

Round Installed Height

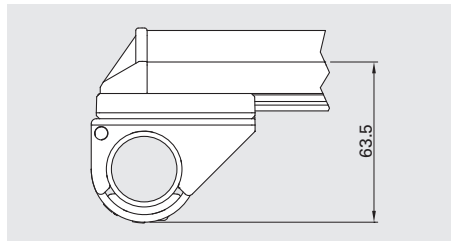

Application

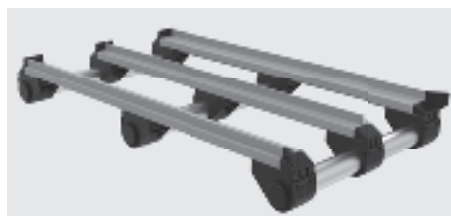

MAT 3031

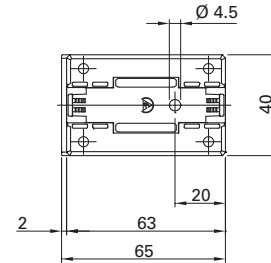
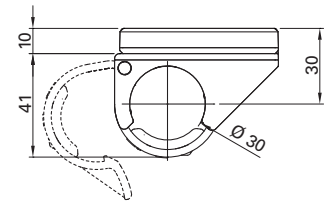

MAT 3033

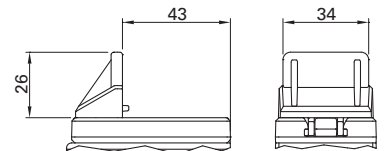

MAT 3035

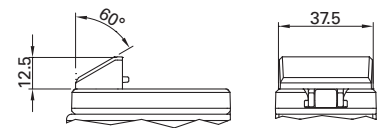

MAT 3037

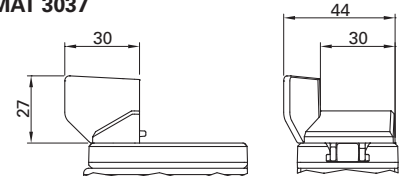

MAT 3039

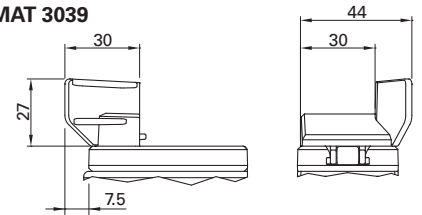

MAT 3033



MAT 3035



MAT 3037



MAT 3039



Order Code

Description	Scope of Delivery					Order Code	Weight
	Base Part	Clamping Part	Adapter plate	Insert	BKS 2x07		
Tube Adapter ESD Kit	1	1	1	-	1	MAT 3031	0.054 kg
Tube Adapter ESD Stop Kit	1	1	1	1 (stop)	1	MAT 3033	0.061 kg
Tube Adapter ESD Flat Kit	1	1	1	1 (flat)	1	MAT 3035	0.059 kg
Tube Adapter ESD Left Kit	1	1	1	1 (left)	1	MAT 3037	0.060 kg
Tube Adapter ESD Right Kit	1	1	1	1 (right)	1	MAT 3039	0.060 kg

Drawing dimensions in mm

MAT 403_

Extrusion Adapter

MAT 4031

**Application**

Adapter to connect the extrusion to the Sliding Rail

Technical Data

Material: Adapter plate PA6, black (ESD conductive) Inserts: PA6, black (ESD conductive) Fastening material: galvanized steel

MAT 4031

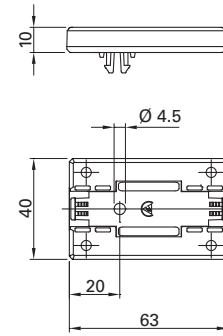

MAT 4033



Surface resistance per Extrusion Adapter
 $R_s < 35 \text{ M}\Omega$

ESD Conductivity

To attach to the extrusion cut off tabs flush

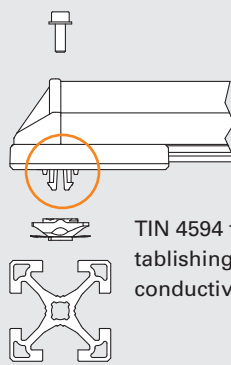

MAT 4033

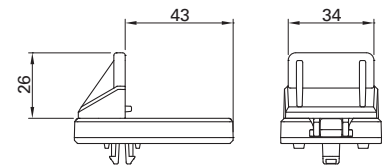

MAT 4035



MAT 4035

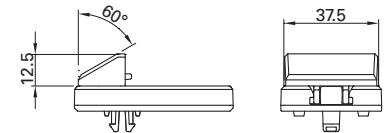

MAT 4037



MAT 4037

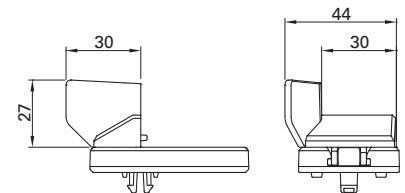

MAT 4039

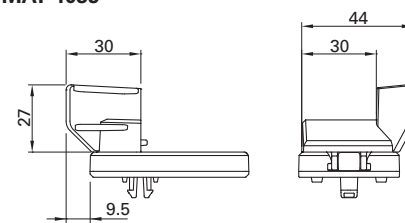
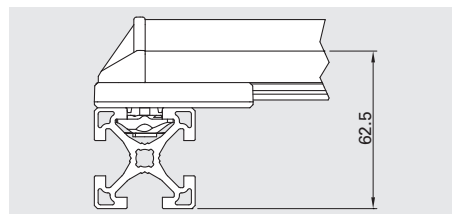
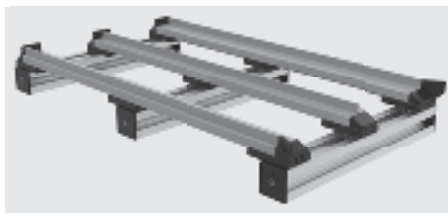

MAT 4039

**Round Installed Height****Application****Order Code**

Description	Scope of Delivery						Order Code	Weight
	Adapter plate	Insert	SKS M04x012	BLS M004	TIN 4594			
Extrusion Adapter ESD Kit	1	-	1	1	1	MAT 4031	0.027 kg	
Extrusion Adapter ESD Stop Kit	1	1 (stop)	1	1	1	MAT 4033	0.034 kg	
Extrusion Adapter ESD Flat Kit	1	1 (flat)	1	1	1	MAT 4035	0.032 kg	
Extrusion Adapter ESD Left Kit	1	1 (left)	1	1	1	MAT 4037	0.033 kg	
Extrusion Adapter ESD Right Kit	1	1 (right)	1	1	1	MAT 4039	0.033 kg	

Drawing dimensions in mm

MAT 903_

Adapter

MAT 9031



Application

Connector for fastening the Sliding Rail for protruding sections or partitioned Sliding Rails

Technical Data

Material: Adapter plate PA6, black (ESD conductive)
 Inserts: PA6, black (ESD conductive)
 Fastening material: galvanized steel

MAT 9031

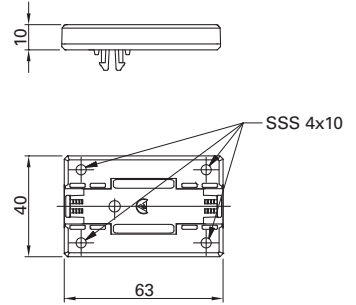

MAT 9033



Surface resistance per Adapter
 $R_s < 35 \text{ M}\Omega$

Round Protrusion

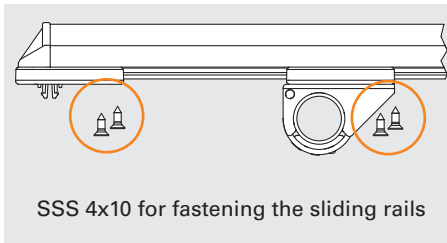

MAT 9033

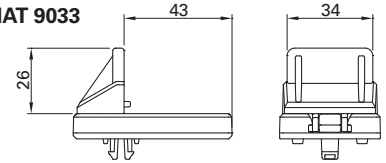

MAT 9035



MAT 9035

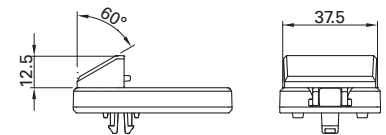

MAT 9037



MAT 9037

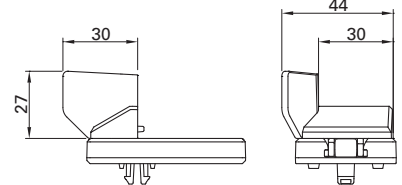

MAT 9039



MAT 9039

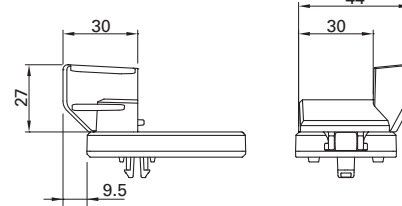

Square Protrusion

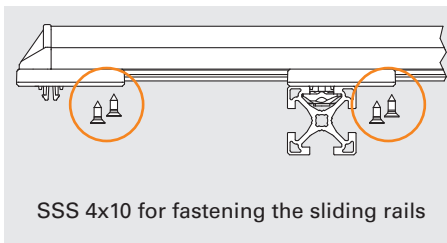

Partitioning

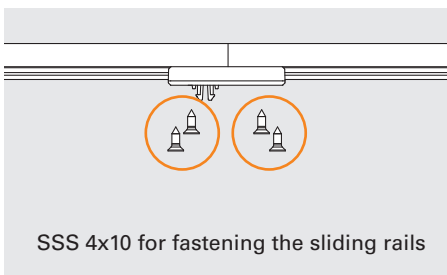

Order Code

Description	Scope of Delivery			Order Code	Weight
	Adapter plate	Insert	SSS 4x10		
Adapter ESD Kit	1	-	4	MAT 9031	0.017 kg
Adapter ESD Stop Kit	1	1 (stop)	4	MAT 9033	0.024 kg
Adapter ESD Flat Kit	1	1 (flat)	4	MAT 9035	0.022 kg
Adapter ESD Left Kit	1	1 (left)	4	MAT 9037	0.023 kg
Adapter ESD Right Kit	1	1 (right)	4	MAT 9039	0.023 kg

Drawing dimensions in mm

PIL 3002

Round Tube 30x2

**Application**

- Universally useful, e.g. as
- Material flow technology
 - Manual workstations
 - In- and out-feed conveyors
 - Signage and shelving
 - Transport carts
 - Table frames

Technical Data

Material: EN AW-6063-T66 clear anodized aluminum

Section modulus $W_x = W_y$: 1.16 cm³

Area moment of inertia

against x + y $I_x = I_y$: 1.73 cm⁴

against torsion I_t : 3.47 cm⁴

Cross sectional area A: 175.9 mm²

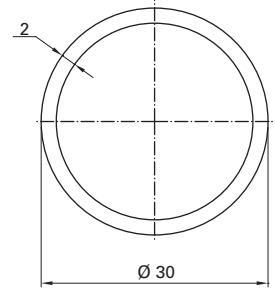

Order Code

Description	Order Code ¹		Weight/Meter
	Length		
Round Tube 30x2, cut to length	PIL 3002 SNN ____		0.475 kg
Round Tube 30x2, stock length 6050 mm (usable length 6000 mm)	PIL 3002 NNN 6050		0.475 kg
Round Tube 30x2, 175 units, stock length 6050 (usable length 6000 mm)	PIL 3002 PAC 0175		0.475 kg

CAP 3002

End Cap For Round Tube 30x2

**Application**

End Cap for Round Tube

Technical Data

Material: PE, black

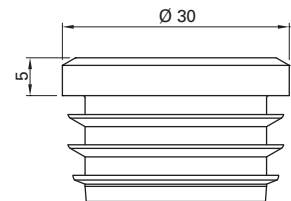

Order Code

Description	Order Code	Weight
End Cap For Round Tube 30x2	CAP 3002	0.004 kg

1) Please complete the order code by adding the desired length.

Drawing dimensions in mm

MAT 3050

Label Holder 50x100

**Application**

Labels can be inserted into transparent
Label Holder
Label Holder can be snapped on
directly to RoundTube

Technical Data

Material: PVC transparent

Max. label size 50 x 100 mm

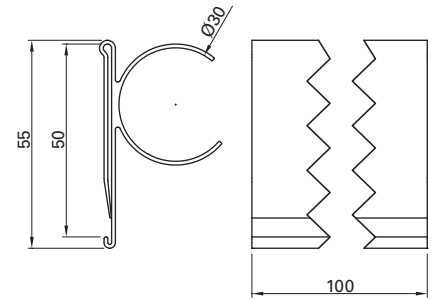

Order Code

Description	Order Code	Weight
Label Holder 50x100	MAT 3050	0.023 kg

Drawing dimensions in mm

