



ROBOTUNITS®

SYSTEMATICALLY. BETTER. TOGETHER.

PROJECT:



TURNTABLE

Assembly Instructions

TABLE OF CONTENTS

1.	General information	3
1.1	System manufacturer	3
1.2	Version	3
2.	Safety	4
2.1	Intended use	4
2.2	Safety instructions for transportation	5
3.	Technical data	6
3.1	Mechanical	6
3.2	Conveyed material	6
3.3	Ambient conditions	6
4.	Mechanical design	7
5.	Assembly	8
5.1	Personnel requirements	8
5.2	Attachment to the Robotunits Roller Conveyor frame	8
5.3	Anchoring to the floor	9
6.	Functions	10
6.1	Rotation	10
6.2	Reference run	11
7.	Maintenance: cleaning and inspection	13
8.	Corrective maintenance and troubleshooting	14
8.1	Maintenance table	14
8.2	Timing belt change	15
8.3	Motor change	16
9.	Components used	17
9.1	Motor roller	17
9.2	Gear motor	17
9.3	Timing belt	17
9.4	Motor controller	18
9.5	Zone and control sensor for Powered Roller Conveyor on the Turntable	18
9.6	Zone sensor for Powered Roller Conveyor	18

1. GENERAL INFORMATION

1.1 SYSTEM MANUFACTURER

Robotunits GmbH
Dr. Walter Zumbel Str. 2
A-6850 Dornbirn
Tel. +43 5572 22000 200
Fax +43 5572 22000 9200
info@robotunits.com
www.robotunits.com

1.2 VERSION

Version	Type	Date
01	Translation of original document	24.01.2023

2. SAFETY

2.1 INTENDED USE

The turntable complements the Robotunits roller conveyor system and is used to turn conveyed goods to the correct position. For technical data, see chapter 3.

Since the turntable is supplied without a control system, it is a "partly completed machine" as described in the Machinery Directive 2006/42/EC.



See appendix for Declaration of Incorporation.

The turntable is mechanically designed with the appropriate covers.



With the installation or completion of a system, the "Integration of Safety" must be taken into account. The integrator or operator must ensure that further suitable protection and safety equipment are implemented where required.

2.2 SAFETY INSTRUCTIONS FOR TRANSPORTATION

 DANGER	
 	<p>Death or serious injury due to lifted load</p> <p>When transporting the turntable, there is a risk of fatal injury from falling loads.</p> <ul style="list-style-type: none">➤ Use a suitable means of transportation.➤ Consider the center of gravity when lifting the machine.➤ Standing under the load is prohibited.

3. TECHNICAL DATA

3.1 MECHANICAL

- Weight of conveyed material: kg (max. 50 kg)
- Weight of turntable: max. 100 kg (depending on version)
- Roller pitch: mm
- Cycle time: min. 10.3 s
- Travel time 90° turn: ≥ 2.5 s
- Powered roller conveyor speed: m/min
- Airborne noise emission: 67 dBA

3.2 CONVEYED MATERIAL

- Dimension: mm
- Material:

3.3 AMBIENT CONDITIONS

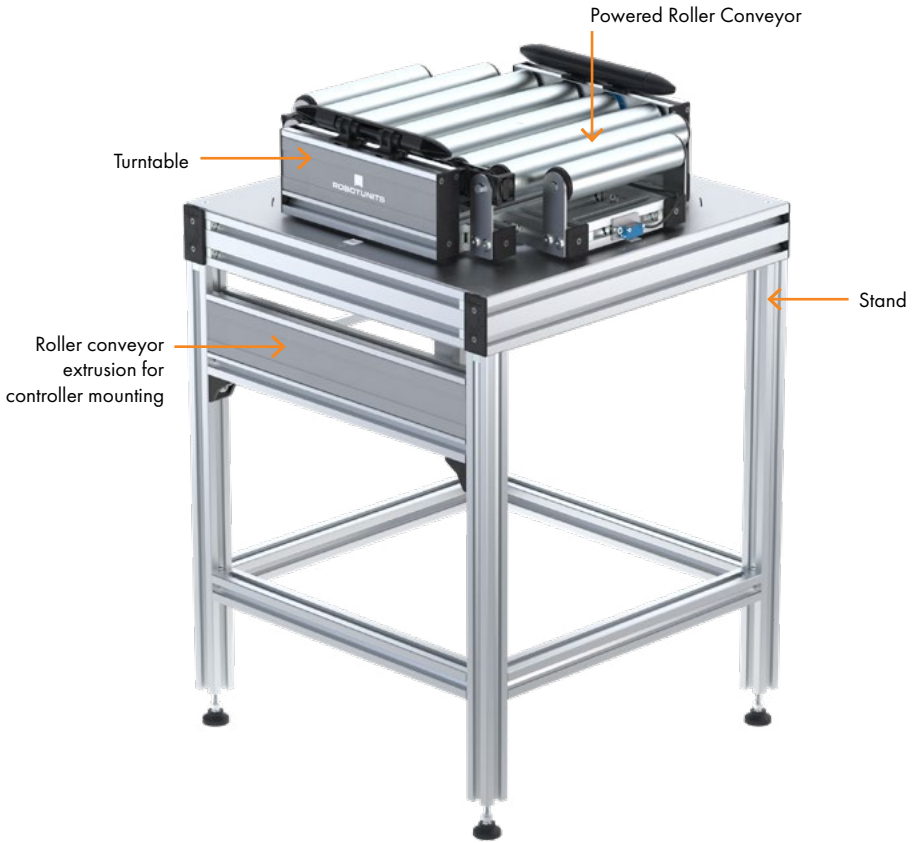

- Ambient temperature: + 2°C to + 40°C
(avoid thermal shocks)
- Humidity: < 90%
- Vibrations: < 0.5g

4. MECHANICAL DESIGN



5. ASSEMBLY

The turntable is delivered as a turnkey solution, completely assembled as described in chapter 4.

 WARNING	
 	<p>Risk of injury due to tipping of the turntable</p> <p>Risk of crushing and shearing injuries to the upper and lower limbs</p> <ul style="list-style-type: none">➤ Secure the machine against tipping over during all operations

5.1 PERSONNEL REQUIREMENTS

All work on the machine must be carried out by qualified and authorized specialists.

5.2 ATTACHMENT TO THE ROBOTUNITS ROLLER CONVEYOR FRAME

Attach the turntable to the Robotunits Roller Conveyor frame using the Robotunits GUS 4501 Corner Bracket and, if necessary, an extrusion for height adjustment.

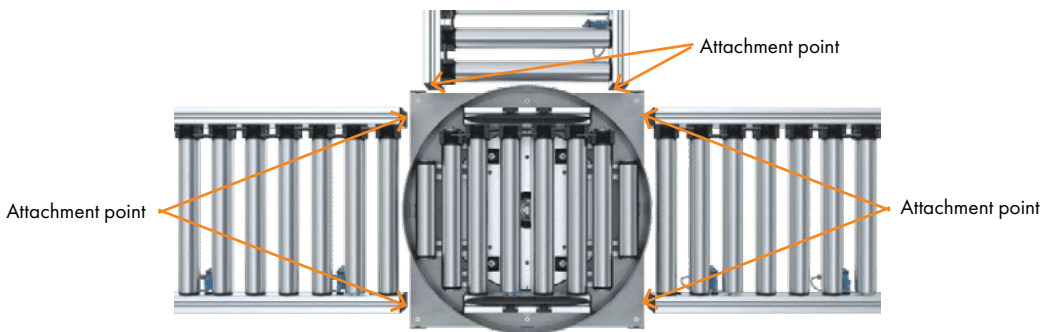

5. ASSEMBLY

5.3 ANCHORING TO THE FLOOR

The turntable is provided with BAS1120 leveling bases with mounting plate and can be fixed to the floor using Robotunits BAP2900 anchor bolts.



Illustration: Leveling Base BAS4008



Illustration:
Mounting Plate BAP4500

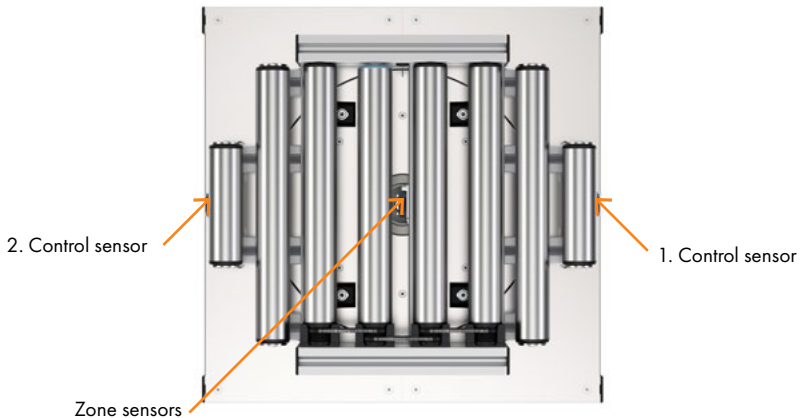
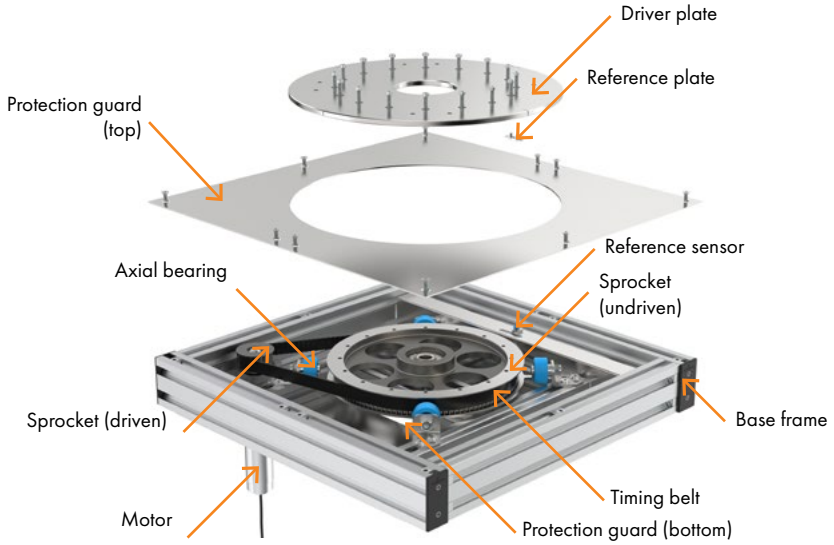

Illustration: Anchor Bolt BAP2900

6. FUNCTIONS

6.1 ROTATION

The turntable is driven by a brushless 24V gear motor, which can be used like a servo motor. The transfer points are monitored by two control sensors. If the control sensor detects an object, the turntable is not allowed to be rotated.



6. FUNCTIONS

6.2 REFERENCE RUN

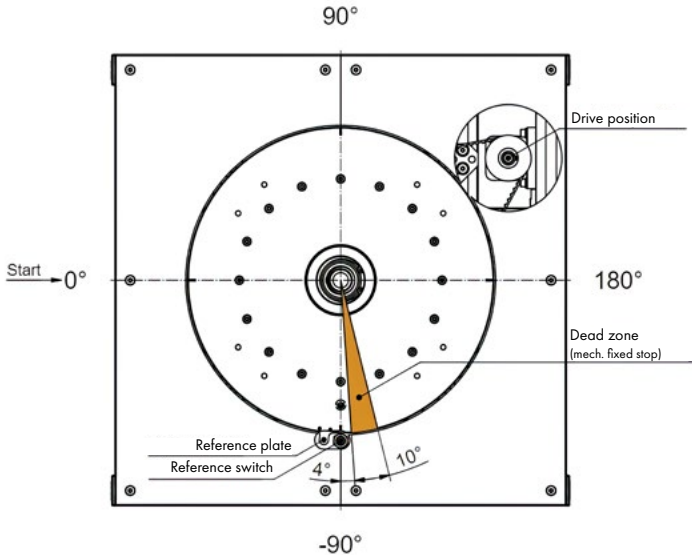

Motor pulses

Turntable side length $\Rightarrow 590\text{mm} = 10,232 \text{ pulses} / 360^\circ$

Turntable side length $\Rightarrow 790\text{mm} = 17,541 \text{ pulses} / 360^\circ$

Procedure

1. Move to zero position.
2. Write integer value "1" to "ServoControlCommandRight".
 - ✓ Zero position is defined. From this point onwards, all distances, which can be both positive and negative, refer to this position.
 - ✓ The module acknowledges the acceptance of the zero position by setting bit 1 in "ServoStatus-Right".
3. Write integer value "0" to ServoControlCommandRight.
 - ✓ Readiness of the module is acknowledged by clearing all bits in "ServoStatusRight".
4. Write the distance to move the turntable as an integer value in "ServocontrolDistanceRight".

6. FUNCTIONS

Example: By writing the integer value as "2", the turntable is moved to the set position. During movement, bit 2 is set in "ServoStatusRight". Reaching the position is acknowledged by setting bit 0 and bit 2 in "ServoStatusRight".

New move command / new zero positioning

By writing the integer value "0" into "ServoControlCommandRight", the module is ready to accept a new move command or zero positioning. Readiness is indicated by deleting all bits in "ServoStatusRight".

During all operations the current position is displayed in "DistanceRight". The same procedure is applicable to the left motor.

7. MAINTENANCE: CLEANING AND INSPECTION

Proper maintenance of the machine is essential for reliable operation and a long service life.

Work to be performed by the operating personnel:

- > Machine shutdown
- > Clean with dry or slightly damp soft cloths
- > Use a vacuum cleaner to remove larger quantities of contamination.
- > Clean sensors, if necessary.
- > Visual inspection for damage; if necessary, request repair from the plant maintenance department

8. CORRECTIVE MAINTENANCE AND TROUBLESHOOTING

The spare parts list can be found in the appendix.

Work to be carried out by trained specialists from the plant maintenance department:

8.1 MAINTENANCE TABLE

Maintenance location	Maintenance interval	Task
Electrical installations	2 times per year	visual inspection for damages and check for tight fit
Timing belt	2 times per year	visual inspection for damages (such as cracks or porosity)
Bearing	2 times per year	check for tight fit
Screw connection after initial commissioning	1 month after initial commissioning	check for tight fit
Screw connections	once a year	check for tight fit
Sensor	as required	remove any dirt that may be present

8. CORRECTIVE MAINTENANCE AND TROUBLESHOOTING

8.2 TIMING BELT CHANGE



1. Remove powered roller conveyor incl. wiring



2. Remove the protection guard and driver plate

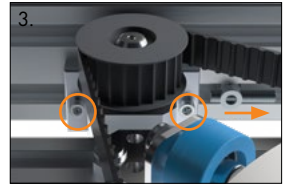

3. Slacken the sprocket



4. Change timing belt

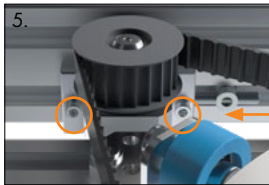

5. Tension the timing belt

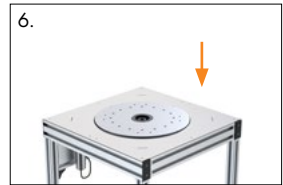

6. Mount the protection guard and driver plate



7. Attach and wire the powered roller conveyor



8. CORRECTIVE MAINTENANCE AND TROUBLESHOOTING

8.3 MOTOR CHANGE

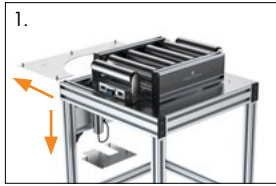

1. Remove the motor-side protection guard

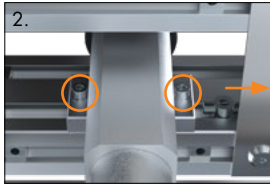

2. Slacken the timing belt and remove the motor

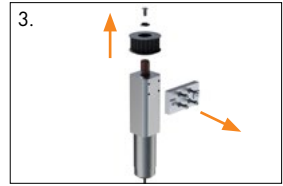

3. Remove the sprocket and motor plate from the motor

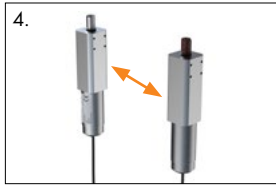

4. Change the motor



5. Attach the sprocket and motor plate to the motor

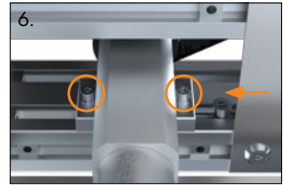

6. Mount the motor and tension the timing belt



7. Mount the protection guard

9. COMPONENTS USED

9.1 MOTOR ROLLER

Motor roller for Powered Roller Conveyor

	<p>Manufacturer: Pulseroller Type: Synergy Ai</p> <p>Item number: 127045 (SC 15) (depending on the design) 127046 (SC 20) 127047 (SC 35)</p>
---	---

9.2 GEAR MOTOR

Gear motor for Turntable

	<p>Manufacturer: Pulseroller Type: PGD-Ai PGD024-SE2-67AAA Speed code 15</p> <p>Item number: 306258</p>
---	--

9.3 TIMING BELT

Timing belt for Turntable

	<p>Manufacturer: Megadyne Type: 1120-SLV2-8-20 1800-SLV2-8-20</p> <p>Item number: 313184 (590) (depending on the design) 311871 (790)</p>
---	--

9. COMPONENTS USED

9.4 MOTOR CONTROLLER

Motor controller for motor roller

	<p>Manufacturer: Pulseroller Type: ConveyLinX Ai2 / MotionLinX Ai Item number: 297340 / 297341 (depending on the design)</p>
---	---

9.5 ZONE AND CONTROL SENSOR FOR POWERED ROLLER CONVEYOR ON THE TURNTABLE

- > For detecting products in the zone of the Turntable
- > For checking whether the product is in the correct position (control sensors)

	<p>Manufacturer: Wenglor Type: P1KY102 Item number: 313262</p>
--	---

9.6 ZONE SENSOR FOR POWERED ROLLER CONVEYOR

- > Sensor for reference run

	<p>Manufacturer: Sick Type: IME12-04BPSZC0S Item number: 145392</p>
---	--

A photograph of a whiteboard with several white markers and a black marker resting on it. A large, stylized teal 'X' is overlaid on the image.

SYSTEMATICALLY >>>>
>>> BETTER TOGETHER.

We reserve the right to alter technical specifications at any time.
We assume no liability for typesetting and printing errors.

Austria • Germany • Switzerland • Italy • France • Spain • Czech Republic • USA • Australia

www.robotunits.com