



ROBOTUNITS®

SYSTEMATICALLY. BETTER. TOGETHER.

PROJECT:



TURNTABLE

Operating Instructions

TABLE OF CONTENTS

1.	General information	3
1.1	System manufacturer	3
1.2	Version	3
2.	Safety	4
2.1	Intended use	4
2.2	Reasonably foreseeable misuse	4
2.3	General safety instructions	5
2.4	Safety equipment	5
3.1	Mechanical	7
3.2	Conveyed material	7
3.3	Layout	7
3.4	Electrical	7
3.5	Ambient conditions	7
3.	Technical data	7
4.	Mechanical design	8
5.	Operating modes	9
5.1	Convey to the left	9
5.2	Convey to the right	10
6.	Transport and storage	11
6.1	Storage/transport conditions	11
6.2	Transportation equipment requirements	11
7.	Commissioning	12
7.1	Personnel requirements	12
7.3	Connecting the machine	12
7.4	Turning range	13
7.5	Initial commissioning	13
8.	Operation	14
9.	Maintenance: Cleaning and inspection	14
10.	Corrective maintenance and troubleshooting	15
10.1	Timing belt change	16
10.2	Motor change	17
11.	Disposal	18
11.1	Wiring/connection diagram	18

1. GENERAL INFORMATION

1.1 SYSTEM MANUFACTURER

Robotunits GmbH
Dr. Walter Zumtobel Str. 2
A-6850 Dornbirn
Tel. +43 5572 22000 200
Fax +43 5572 22000 9200
info.usa1@robotunits.com
www.robotunits.com

1.2 VERSION

Version	Type	Date
01	Translation of the original document	13.01.2023

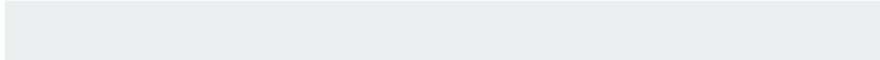

2. SAFETY



2.1 INTENDED USE

The turntable complements the Robotunits roller conveyor system and is used to turn conveyed goods to the correct position. For technical data, see chapter 3.

Since the turntable is supplied with a control system, it is a "complete machine" as described in the Machinery Directive 2006/42/EC. Declaration of conformity: see appendix.

The turntable is designed and built for:

- > transporting parts or liquids in closed totes with zero pressure accumulation.
- > being used in industrial and commercial applications.

 CAUTION	
	<p>Danger due to operation by untrained personnel</p> <p>The turntable may only be operated by trained personnel.</p>

2.2 REASONABLY FORESEEABLE MISUSE





The following is not permitted:

- > the operation of the machine without safety equipment
- > the manipulation, bypassing or disabling of already installed safety equipment
- > using the machine in or under water
- > the transportation of animals or people
- > the transportation of hot substances and objects (> 40°C)
- > the transportation of and usage in acids, corrosive / abrasive materials or substances
- > transportation at excessive speed
- > damages due to improper installation
- > the use in potentially explosive atmospheres
- > the use in corrosive atmospheres

2. SAFETY

2.3 GENERAL SAFETY INSTRUCTIONS

- > observe national laws and regulations on safety and health protection
- > read and understand the operating instructions of the turntable

 DANGER	
  	<p>Danger due to rotating rollers</p> <p>Risk of crushing and shearing injuries to the upper and lower limbs</p> <p>It is not permitted to:</p> <ul style="list-style-type: none">> stand or walk on the turntable or the frame> reach between two rollers during operation> reach between the powered roller conveyor and the ring guard during operation> reach between the drive belt and drive belt head during operation



2.4 SAFETY EQUIPMENT

The turntable may only be operated in its original condition (with all safety equipment). All supplied safety components must be installed and must fulfill the safety function flawlessly.

2. SAFETY



With the installation or completion of a system, the “Integration of Safety” must be taken into account. The integrator or operator must ensure that further suitable protection and safety equipment are implemented where required.

 WARNING	
	<p>Danger due to faulty electrical connection</p> <p>Only connect the turntable using a sufficiently rated power supply unit</p> <ul style="list-style-type: none">> Installation must be carried out by a qualified and authorized electrical specialist> Observe technical data in chapter 3

3. TECHNICAL DATA

3.1 MECHANICAL

- › Weight of conveyed material: kg (max. 50 kg)
- › Weight of turntable: max. 100 kg (depending on version)
- › Roller pitch: mm
- › Cycle time: min. 10.3 s
- › Travel time 90° turn: ≥ 2.5 s
- › Powered roller conveyor speed: m/min
- › Airborne noise emission: 67 dBA

3.2 CONVEYED MATERIAL

For customer-specific data, see supplied "Customer document"

- › Dimension: mm
- › Material:

3.3 LAYOUT

Layout - see appendix!

3.4 ELECTRICAL

Connection data for turntable (without power supply)

- › Control voltage: 24 VDC
- › Continuous current per motor roller: max. 3.5 A
- › Starting current per motor roller: max. 5 A

Connection data with Robotunits power supply

- › Voltage: 400 VAC
- › Connection: CEE plug (16 A)

3.5 AMBIENT CONDITIONS

- › Ambient temperature: + 2°C to + 40°C
(avoid thermal shocks)
- › Humidity: < 90%
- › Vibrations: < 0.5g

4. MECHANICAL DESIGN

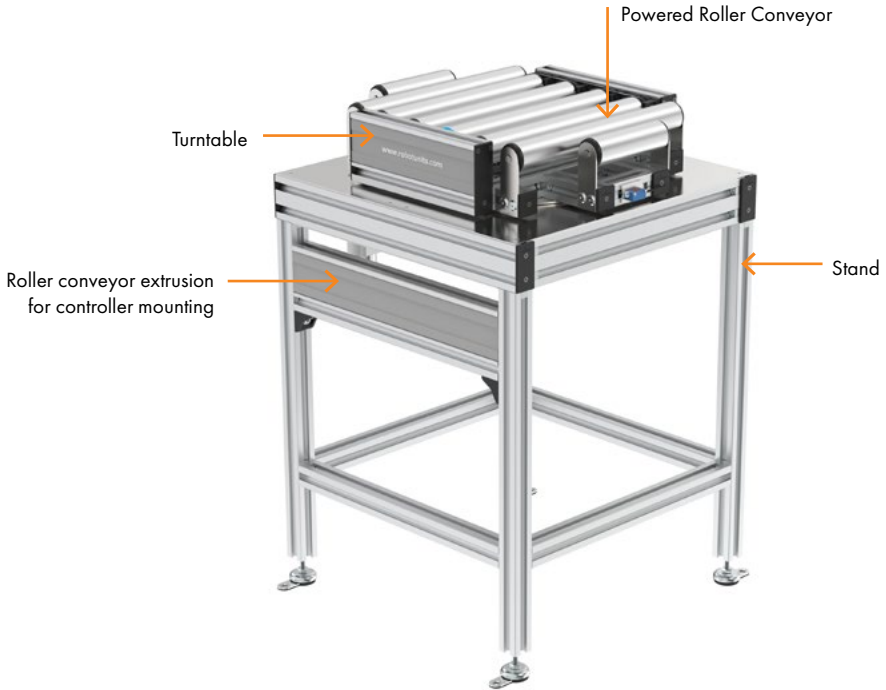

5. OPERATING MODES

5.1 CONVEY TO THE LEFT

The product continues to be conveyed in the same orientation:

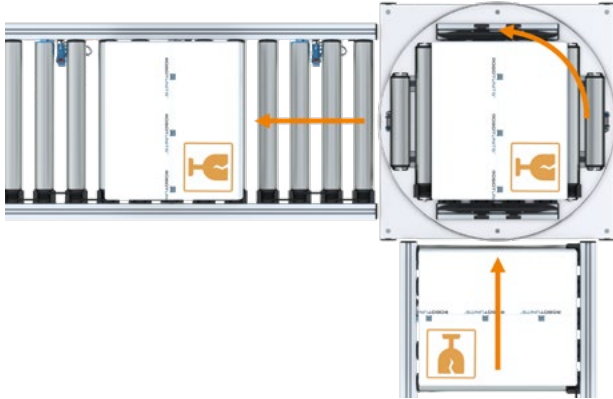

The product is rotated by 180° and conveyed onwards:

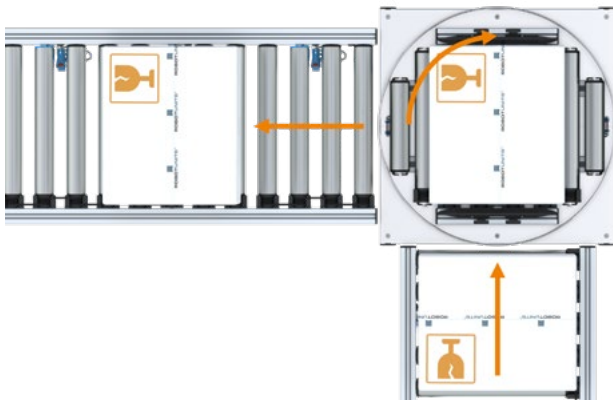

5. OPERATING MODES

5.2 CONVEY TO THE RIGHT

The product continues to be conveyed in the same orientation:

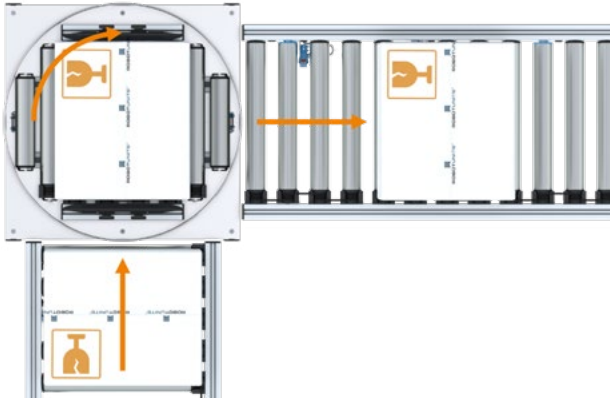

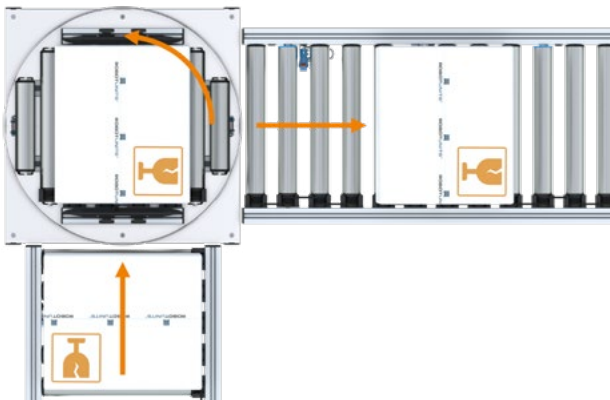

The product is rotated by 180° and conveyed onwards:





6. TRANSPORT AND STORAGE

6.1 STORAGE/TRANSPORT CONDITIONS

 WARNING	
 	<p>Risk of injury due to tipping of the turntable</p> <p>Risk of crushing and shearing injuries to the upper and lower limbs</p> <ul style="list-style-type: none">➤ During transport and storage, secure the machine to prevent it from tipping over

NOTICE	
	<p>Material damage due to improper storage</p> <p>Moisture penetration can damage the machine.</p> <ul style="list-style-type: none">➤ Do not store outdoors

6.2 TRANSPORTATION EQUIPMENT REQUIREMENTS

 DANGER	
 	<p>Death or serious injury due to lifted load</p> <p>When transporting the turntable, there is a risk of fatal injury from falling loads.</p> <ul style="list-style-type: none">➤ Use a suitable means of transportation.➤ Consider the center of gravity when lifting the machine.➤ Standing under the load is prohibited.

7. COMMISSIONING

7.1 PERSONNEL REQUIREMENTS

All work on the machine must be carried out by qualified and authorized specialists.





7.2 ASSEMBLY OF THE MACHINE

Observe the assembly instructions.

Attach the machine to the Robotunits powered roller conveyor frame.

7.3 CONNECTING THE MACHINE

The machine must be connected by a trained electrician

 DANGER	
  	<p>Death or serious injury from electric shock</p> <p>There is a risk of electric shock due to improper wiring and inadequate protective grounding.</p> <ul style="list-style-type: none">➤ Measures regarding electromagnetic compatibility (EMC) must be observed➤ Ensure continuous potential equalization➤ Check the function and proper condition of the turntable

- Observe wiring diagram (see appendix)
- Connect frame with protective grounding
- Connect the OV of the power supply unit with protective grounding
- If the machine is positioned near a workplace, install a mains disconnection device for switching off in an emergency

7. COMMISSIONING

7.4 TURNING RANGE

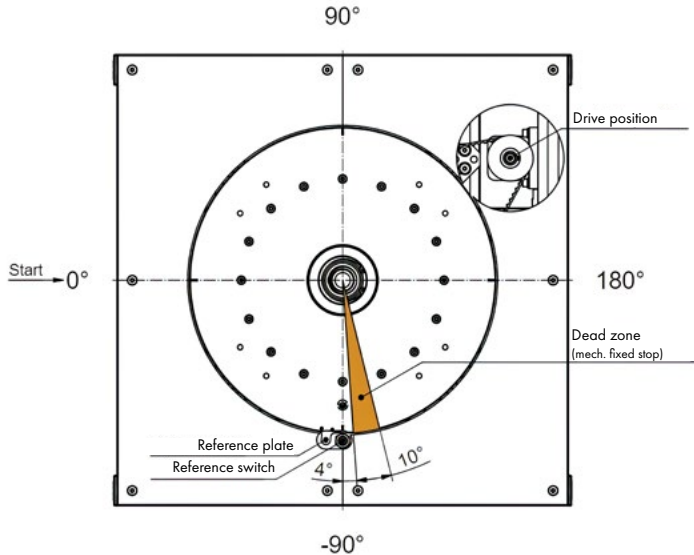





7.5 INITIAL COMMISSIONING

Before initial commissioning, check the following:

1. The proper installation of all safety equipment and covers. In case of an increased risk of conveyed material possibly falling down, additional safety equipment must be installed.
2. The proper connection of the turntable to the conveyor system.
3. The speed and running direction after the first operation of the powered roller conveyor.



8. OPERATION

The turntable is ready for operation immediately after being switched on and is in the start position as described in 7.3.

 DANGER	
  	<p>Danger due to rotating rollers and falling conveyed products</p> <p>Risk of crushing and shearing injuries to the entire body</p> <ul style="list-style-type: none">> wear tight-fitting work clothes> in case of long hair, wear a hair net> wear safety shoes with protective caps

9. MAINTENANCE: CLEANING AND INSPECTION

Proper maintenance of the machine is essential for reliable operation and a long service life.

 WARNING	
 	<p>Danger due to rotating rollers</p> <p>Risk of crushing injuries to hands and fingers</p> <ul style="list-style-type: none">> Switch off the machine before carrying out any cleaning work



Work to be performed by the operating personnel:

- > Machine shutdown
- > Clean with dry or slightly damp soft cloths
- > Use a vacuum cleaner to remove larger quantities of contamination.
- > Clean sensors, if necessary.
- > Visual inspection for damage; if necessary, request repair from the plant maintenance department

10. CORRECTIVE MAINTENANCE AND TROUBLESHOOTING

The spare parts list can be found in the appendix.

Work to be carried out by trained specialists from the plant maintenance department:

 WARNING	
 	<p>Danger due to rotating rollers</p> <p>Risk of crushing injuries to hands and fingers</p> <p>➤ Switch off the machine before carrying out any maintenance work</p>

Maintenance schedule

Maintenance location	Maintenance interval	Task
Electrical installations	2 times per year	visual inspection for damages and check for tight fit
Timing belt	2 times per year	visual inspection for damages (such as cracks or porosity)
Bearing	2 times per year	check for tight fit
Screw connections after initial commissioning	1 month after initial commissioning	check for tight fit
Screw connections	once a year	check for tight fit
Sensor	in case of malfunctions	remove any dirt that may be present

10. MAINTENANCE, REPAIR AND TROUBLESHOOTING

10.1 TIMING BELT CHANGE



1. Remove powered roller conveyor incl. wiring 



2. Remove the protection guard and driver plate 

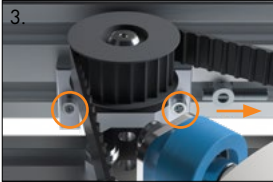

3. Slacken the timing belt 



4. Change timing belt 

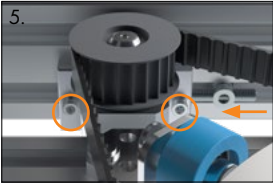

5. Tension the timing belt 

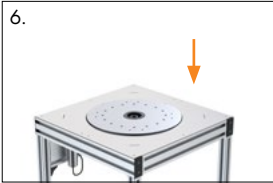

6. Install protection guard and driver plate 



7. Fasten and wire the powered roller conveyor 

10. MAINTENANCE, REPAIR AND TROUBLESHOOTING

10.2 MOTOR CHANGE



1. Remove the motor-side protection guard

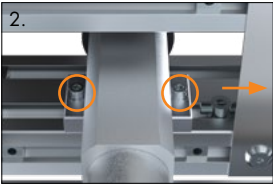

2. Slacken the timing belt and remove the motor

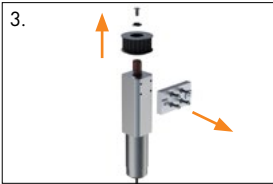

3. Remove the timing belt pulley and motor plate from the motor

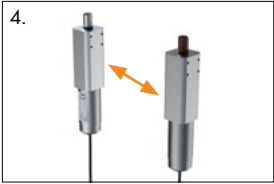

4. Change the motor



5. Attach the timing belt pulley and motor plate to the motor

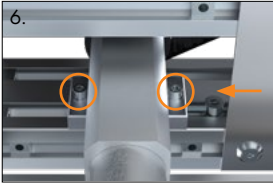

6. Install the motor and tension the timing belt



7. Install the protection guard

11. DISPOSAL

The product contains valuable materials (metals, plastics, electrical assemblies) which can be separated and recycled.

At the end of its service life, the machine must be taken to a specialist disposal center.

11.1 WIRING/CONNECTION DIAGRAM

See appendix.

A photograph of a whiteboard with several white markers and a black marker resting on it. A large, stylized teal 'X' graphic is overlaid on the image.

SYSTEMATICALLY >>>>
>>> BETTER TOGETHER.

We reserve the right to alter technical specifications at any time.
We assume no liability for typesetting and printing errors.

Austria • Germany • Switzerland • Italy • France • Spain • Czech Republic • USA • Australia

www.robotunits.com