

Project:



**Transfer Unit 90°, 100**

Assembly Instructions



## Table of contents

<b>1.</b>	<b>General information</b> .....	<b>4</b>
1.1	System manufacturer .....	4
1.2	Version .....	4
<b>2.</b>	<b>Safety</b> .....	<b>5</b>
2.1	Intended use .....	5
2.2	Personnel requirements .....	5
2.3	Safety components .....	5
2.4	Safety instructions for transport and storage .....	6
2.5	Residual risks .....	7
<b>3.</b>	<b>Technical data</b> .....	<b>8</b>
3.1	Mechanical .....	8
3.2	Electrical .....	8
3.3	Conveyed material .....	8
3.4	Ambient conditions .....	8
<b>4.</b>	<b>Mechanical design</b> .....	<b>9</b>
<b>5.</b>	<b>Accessories</b> .....	<b>10</b>
<b>6.</b>	<b>Functions</b> .....	<b>10</b>
6.1	Lifting unit motor (absolute positioning) .....	11
6.2	Reference travel .....	11
6.3	Lifting unit motor (positioning to setpoint position) .....	11
6.4	Connection and control of lifting unit motor .....	12
6.5	Speed control on the transfer lane motor .....	13
6.6	Connection and control of timing belt motor .....	13
<b>7.</b>	<b>Notes on programming the Transfer Unit 90°</b> .....	<b>14</b>
<b>8.</b>	<b>Maintenance, servicing and cleaning</b> .....	<b>15</b>
<b>9.</b>	<b>Maintenance, repair and troubleshooting</b> .....	<b>16</b>
9.1	Transfer lane belt .....	17
9.2	Transfer lane motor .....	18
9.3	Lifting unit motor .....	19
<b>10.</b>	<b>Components used</b> .....	<b>20</b>
10.1	Lifting unit motor .....	20
10.2	Timing belt motor .....	20
10.3	Roller conveyor zone sensor in the Transfer Unit 90° zone .....	20
<b>11.</b>	<b>EU Declaration of Incorporation</b> .....	<b>22</b>

# 1. General information

## 1.1 System manufacturer

Robotunits GmbH  
Dr. Walter Zumtobel Str. 2  
A-6850 Dornbirn  
Tel.: +43 5572 22000 200  
E-Mail: info@robotunits.com

## 1.2 Version

Version	Type	Date
01	New document	25.05.2024

## 2. Safety

### 2.1 Intended use

The Transfer Unit 90° complements the Robotunits Powered Roller Conveyor system, enabling a 90° transfer of conveyed material. For technical data, see chapter 3.

As the Transfer Unit 90° is supplied without a control system, it is 'partly completed machinery' as described in the Machinery Directive 2006/42/EC.

See chapter 11 for the Declaration of Incorporation.

The Transfer Unit 90° is to be used only in conjunction with a Robotunits Powered Roller Conveyor.

### 2.2 Personnel requirements

All work on the machine must be carried out by qualified and authorized specialists.

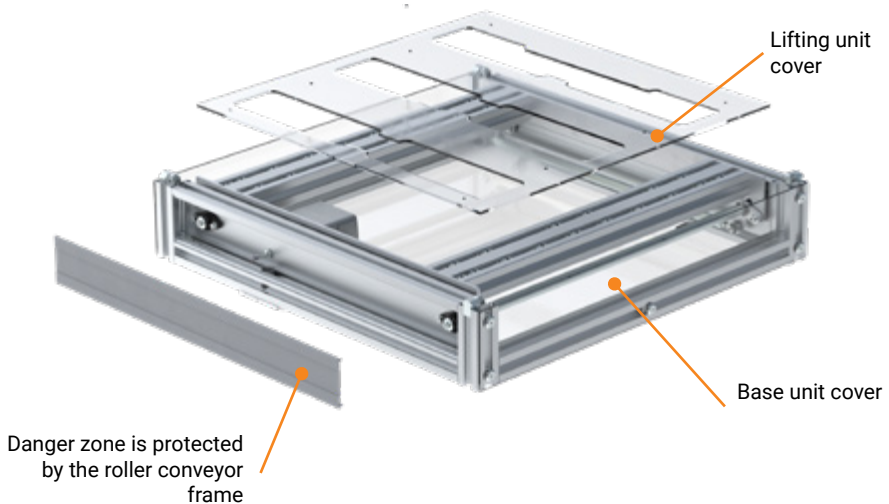

### 2.3 Safety components

The Transfer Unit 90° is designed with the following covers:





## 2.4 Safety instructions for transport and storage

### Storage/transport conditions

 <b>WARNING</b>	
	<p><b>Risk of injury when carrying the Transfer Unit 90°</b></p> <p>Risk of crushing and shearing injuries to the upper and lower limbs</p> <ul style="list-style-type: none"><li>• Wear safety shoes</li></ul>





<b>NOTICE</b>	
	<p><b>Material damage due to improper storage</b></p> <p>Moisture penetration can damage the machine.</p> <ul style="list-style-type: none"><li>• Do not store outdoors</li></ul>

### Transportation equipment requirements

 <b>DANGER</b>	
 	<p><b>Death or serious injury due to lifted load</b></p> <p>During transport there is a risk of fatal injury from falling loads.</p> <ul style="list-style-type: none"><li>• Use a suitable means of transportation.</li><li>• Consider the center of gravity when lifting the machine.</li><li>• Standing under the load is prohibited.</li></ul>

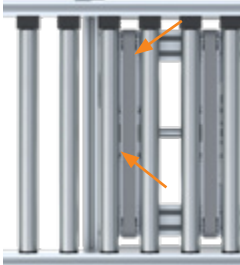
## 2.5 Residual risks

When installing the Transfer Unit 90° in a Powered Roller Conveyor system, new danger zones may arise.

Phase of life	Risk and avoidance	
Commissioning and operation	<p>Retraction of fingers or hands during rotary movement of the rollers or when lowering the transfer lanes</p>  <ul style="list-style-type: none"><li>• Do not reach in during operation</li><li>• Install the cover</li><li>• Install appropriate guard (e.g. movable guard)</li></ul>	
Commissioning and operation	<p>Injury due to falling conveyed material: In the event of a malfunction (e.g. incorrect conveying direction) or failure of the control unit, the conveyed material may fall to the floor!</p>  <ul style="list-style-type: none"><li>• Install end stop or suitable side guides</li><li>• Close off the area</li></ul>	

## 3. Technical data

### 3.1 Mechanical

- Weight of conveyed material: kg (max. 100 kg, depending on design)
- Weight of Transfer Unit 90°: max. 70 kg (depending on version)
- Roller pitch: mm (min. 105 mm)
- Stroke: 20 mm
- Transfer lane width: 50 mm
- Belt width: 32 mm
- Cycle time (L300xW400): min. 3.5 s with 30 kg
- Speed\*: max. 36 m/min (up to 35 kg)  
max. 13 m/min (with 100 kg)
- Airborne noise emission: 67 dBA

### 3.2 Electrical

- Lifting unit motor: P = 272 W, U = 48 V
- Timing belt motor: P = 356 W, U = 48 V
- Control signals: 24 V

### 3.3 Conveyed material

- Dimension: mm (max. 1000 x 1000 x 1000 mm)
- Material:

### 3.4 Ambient conditions

- Ambient temperature: + 2°C to + 40°C  
(avoid thermal shocks)
- Humidity: < 90 %
- Vibrations: < 0.5 g



## 4. Mechanical design

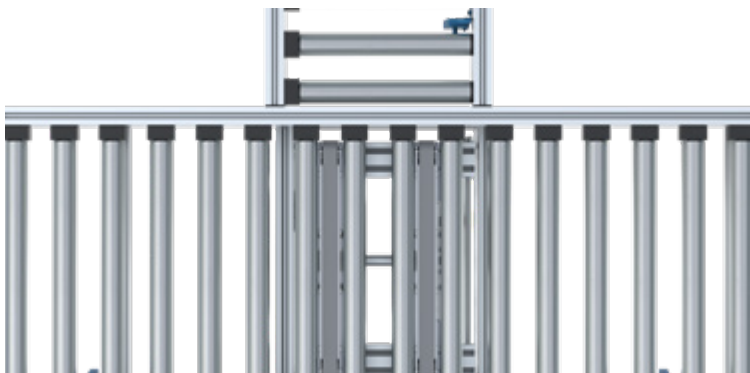
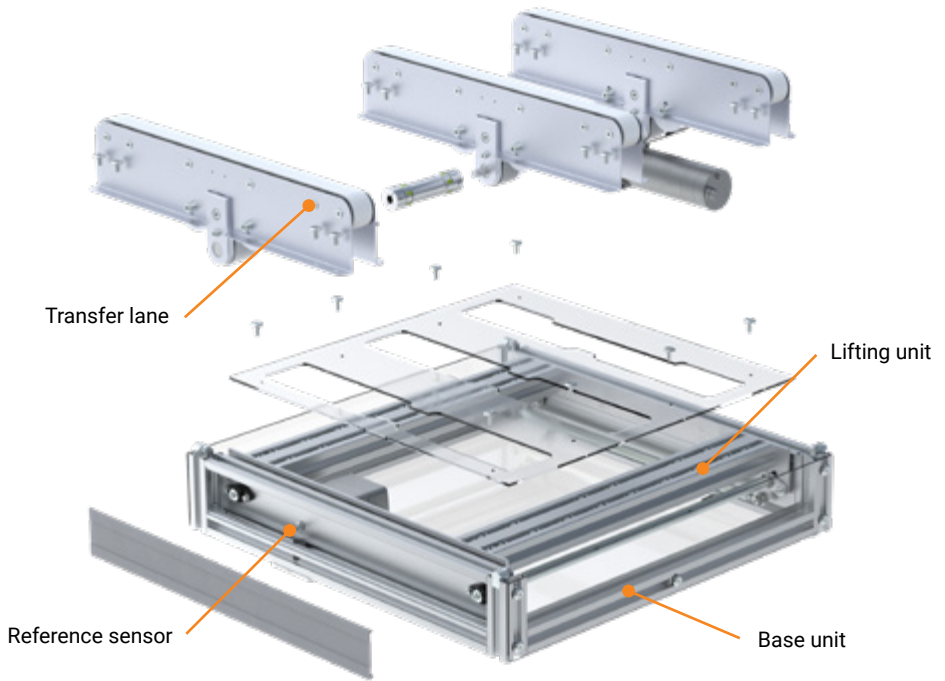

## 5. Accessories

The following table shows the SEW accessories for the compact extra-low voltage drive. With these accessories, the parameters can be configured via the DCA-Shell engineering software.

If no engineering adapter is available, the RJ10 interface cable (see 10.6) can be connected directly to PIN 11 and PIN 12 according to the tables in 6.4 and 6.6.

Option	Description	Type	Item no.
<b>Engineering Adapter</b>	<p>The DCZ-048P-DBC-09 Engineering Adapter is used for the start-up, parameterization and service procedures of the compact extra-low voltage drive.</p> <p>The Engineering Adapter is an intermediate adapter that is temporarily connected between the motor and the customer's system.</p>	DCZ-048P-DBC-09	<p>SEW number: 25655884</p> <p>Robotunits number: 145323</p>
<p><b>Interface adapter</b></p> <p>USB to RS485</p> <p>Internal supply from USB interface</p>	<p>The USM21A is connected to the PC via a USB type B socket. It connects the PC with the DCZ-048P-DBC-09 Engineering Adapter.</p> <p>The data is transferred according to the USB 2.0 standard. It is also possible to work with a USB 3.0 unit.</p> <p>Scope of delivery:</p> <ul style="list-style-type: none"> <li>• USM21A Interface Adapter</li> <li>• USB connection cable</li> <li>• Interface cable with 2 RJ10 connectors</li> </ul>	USM21A	<p>SEW number: 28231449</p> <p>Robotunits number: 193642</p>

Engineering Software:

[https://www.sew-eurodrive.at/os/dud/?tab=software&country=AT&language=en\\_us&search=dca](https://www.sew-eurodrive.at/os/dud/?tab=software&country=AT&language=en_us&search=dca)

## 6. Functions

### 6.1 Lifting unit motor (absolute positioning)

The motor is preset by Robotunits. The upper and lower positions are stored locally in the drive.

### 6.2 Reference travel

The reference travel must be programmed with a PLC. The operational control is coded via 2 binary inputs (see table below).

Terminal status		Function	Description
IN A (PIN 1)	IN B (PIN 2)		
0	0	Locked	Output stage is inhibited. It is active on drives with a holding brake.
0→1 1	0	Reference travel start	Enable with reference travel speed, positive or negative direction of rotation
1	0→1	Set reference value	The current position is set as the reference value with a rising edge at IN B.
1		Position to PX	After the reference travel, positioning is performed to the selected setpoint position in accordance with IN 1 / IN 2

### 6.3 Lifting unit motor (positioning to setpoint position)

Terminal status		Function	Description
IN A (PIN 1)			
0		Locked	Output stage is inhibited. It is active on drives with a holding brake.
1		Enable / Position / Hold	Position to the selected setpoint position in accordance with IN 1 / IN 2

Terminal status		Function	Description
IN 1 (PIN 3)	IN 2 (PIN 4)		
0	0	Setpoint position P1	Position P1 is activated or held.
1	0	Setpoint position P2	Position P2 is activated or held.
0	1	Setpoint position P3	Position P3 is activated or held.
1	1	Setpoint position P4	Position P4 is activated or held.

## 6.4 Connection and control of lifting unit motor

To use the preset parameters, the 15-pin connection cable must be connected as follows. The reference sensor (see chapter 4) must be connected to the control unit.

Plug connector  
on the motor side, M16

Connection cable with M16 plug connector,  
15-pin, 5 m

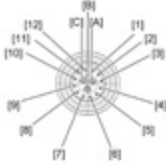

PIN	Cable cross section mm <sup>2</sup>	Conductor color	Connection	Identification	Wiring	24 V signal for reference travel	24 V signal for upper position	24 V Signal for lower position	Interface cable with RJ10 connector USM21A
A	1.5	GY	Braking resistor	Braking resistor	-				
B	1.5	BN	U DC 48V	Voltage supply	x				
C	1.5	BK	GND	Power/signal GND	x				
1	0.25	WH	IN A	Digital input DC 24 V	x	see table 6.2 Reference travel			
2	0.25	BN	IN B	Digital input DC 24 V	x				
3	0.25	GN	IN 1	Digital input DC 24 V	x		0	1	
4	0.25	YE	IN 2	Digital input DC 24 V	x		0	0	
5	0.25	GY	OUT 1	Digital input DC 24 V	-				
6	0.25	PK	OUT 2	Position reached DC 24 V	x				
7	0.25	BU	OUT 3	Ready DC 24 V	x				
8	0.25	RD	Analog IN 1	0...10 V (differential)	-				
9	0.25	BK	Analog GND	GND for Analog IN 1 (diff)	-				
10	0.25	VT	RS485 A (+)	Engineering bus	opt.				BN
11	0.25	GY/BK	RS 485 (-)	Engineering bus	opt.				GN
12	0.25	RD/BU	U DC 24V	Control voltage DC 24 V	x				

The DCA Shell software and the accessories described in chapter 5 are required to change the parameters. In the event of an error, both inputs (IN A and IN B) must be set to "0". The acknowledgement is made via a rising edge at one of the two inputs (IN A or IN B).

## 6.5 Speed control on the transfer lane motor

The motor is preset by Robotunits with the desired speed.

## 6.6 Connection and control of timing belt motor

The 15-pin connection cable must be connected as follows:

<b>Plug connector on the motor side, M16</b>	<b>Connection cable with M16 plug connector, 15-pin, 5 m</b>
--	--

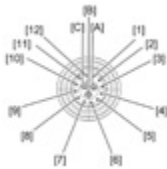

PIN	Cable cross section mm <sup>2</sup>	Conductor color	Connection	Identification	Wiring	24 V signal Start motor in clockwise direction	24 V signal Start motor in counter-clockwise direction	Interface cable with RJ10 connector USM21A
A	1.5	GY	Braking resistor	Braking resistor	-			
B	1.5	BN	U DC 48V	Voltage supply	x			
C	1.5	BK	GND	Power/signal GND	x			
1	0.25	WH	IN A	Digital input DC 24 V	x	1	0	
2	0.25	BN	IN B	Digital input DC 24 V	x	0	1	
3	0.25	GN	IN 1	Digital input DC 24 V	x	0	0	
4	0.25	YE	IN 2	Digital input DC 24 V	x	0	0	
5	0.25	GY	OUT 1	Digital input DC 24 V	-			
6	0.25	PK	OUT 2	Position reached DC 24 V	-			
7	0.25	BU	OUT 3	Ready DC 24 V	-			
8	0.25	RD	Analog IN 1	0...10 V (differential)	-			
9	0.25	BK	Analog GND	GND for Analog IN 1 (diff)	-			
10	0.25	VT	RS485 A (+)	Engineering bus	opt.			BN
11	0.25	GY/BK	RS 485 (-)	Engineering bus	opt.			GN
12	0.25	RD/BU	U DC 24V	Control voltage DC 24 V	x			

The DCA Shell software (online) and the accessories described in chapter 5 are required to change the parameters.

## 7. Notes on programming the Transfer Unit 90°

Action	Description
Reference travel	Lifting unit motor See table 6.2 / 6.4
Initial position	Start lifting unit motor See table 6.2 / 6.4 (PIN 6 = position reached)
Load material on conveyor	Timing belt motor See table 6.6
Perform lift	Lifting unit motor See table 6.4 (PIN 6 = position reached)
Unload conveyed material	Start timing belt motor See table 6.6
Initial position	Lifting unit motor See table 6.2 / 6.4

**CAUTION:**



If the control voltage (24 volts) is switched off, referencing is necessary again.

For further details, see SEW operating instructions for compact extra-low voltage drives:

<https://download.sew-eurodrive.com/download/pdf/26718014.pdf>

## 8. Maintenance, servicing and cleaning



Proper maintenance of the machine is essential for reliable operation and a long service life.

 <b>WARNING</b>	
 	<p><b>Danger due to rotating rollers and lowering of the transfer lanes!</b></p> <p>Risk of crushing injuries to hands and fingers</p> <ul style="list-style-type: none"><li>• Switch off the machine before carrying out any maintenance work</li></ul>

Work to be performed by the operating personnel:

- Clean with dry or slightly damp, soft cloths (Polycarbonate panels are susceptible to scratches)
- Use a vacuum cleaner to remove larger quantities of contamination.
- Clean sensors, if necessary.
- Check tension of timing belt
- Visual inspection for damage; if necessary, request repair from the plant maintenance department

## 9. Maintenance, repair and troubleshooting

 <b>WARNING</b>	
 	<p><b>Danger due to rotating rollers and lowering of the transfer lanes</b></p> <p>Risk of crushing injuries to hands and fingers</p> <ul style="list-style-type: none"> <li>• Switch off the machine before carrying out any maintenance work</li> </ul>

The spare parts list can be found in the appendix.

Work to be carried out by trained specialists from the plant maintenance department:

### Maintenance schedule

Maintenance point / Activity	Maintenance interval	Info
Electrical installations	2 times per year	Visual inspection for damages and check for tight fit
Timing belt	every 3 months	visual inspection for damages (such as cracks or porosity)
Screw connections after initial commissioning	1 month after initial commissioning	check for tight fit
Screw connections	once a year	check for tight fit
Sensor	as required	remove any dirt that may be present



### 9.1 Transfer lane belt

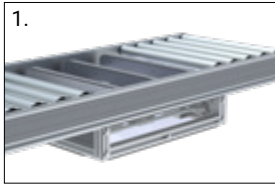

1. Remove the rollers located above the Transfer Unit 90°.

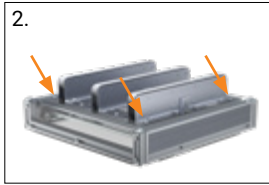

2. Loosen the fastening screws of the transfer lane, the cover and the connection shaft.

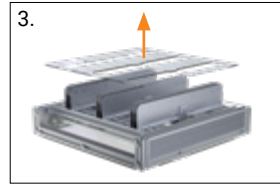

3. Remove the transfer lane, the cover and the connection shaft.

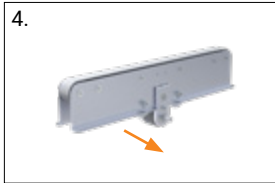

4. Loosen the fastening screws of the side panel and remove the side panel.

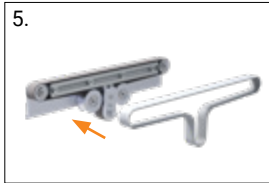

5. Change the belt and, if necessary, the sprockets.

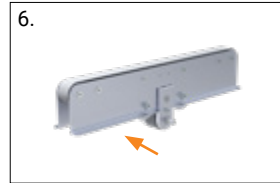

6. Reassemble the side panel and tension the belt.

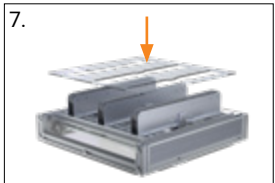

7. Position and screw on the transfer lane, the connection shaft and the cover.

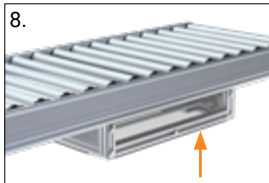

8. Reattach the rollers of the Powered Roller Conveyor

## 9.2 Transfer lane motor

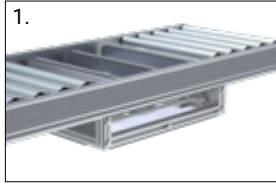

1. Remove the rollers located above the Transfer Unit 90°.

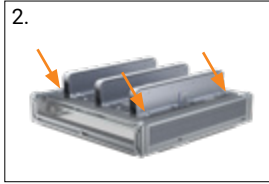

2. Loosen the fastening screws of the transfer lane, the cover and the connection shaft.



3. Remove the transfer lane, the cover and the connection shaft.

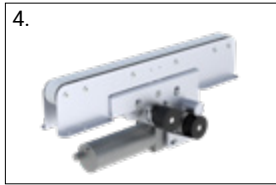

4. Remove the transfer lane with the motor.

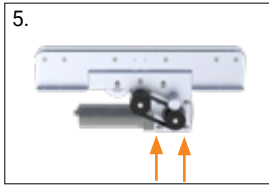

5. Loosen the screws and slacken the belt.

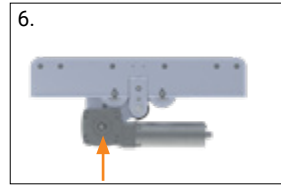

6. Remove the circlip and the shaft with the sprocket.

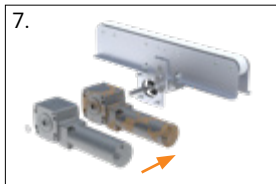

7. Remove and replace the motor.

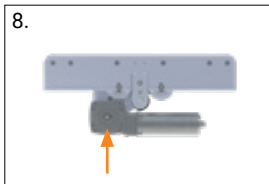

8. Reattach the circlip and the shaft with the sprocket.

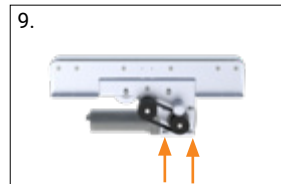

9. Tension the belt and tighten the screws.



10. Position and screw on the transfer lane, the connection shaft and the cover.



11. Reattach the rollers of the Powered Roller Conveyor.

### 9.3 Lifting unit motor

#### Motor roller / conveyor roller replacement



1.  
Remove the bottom cover.

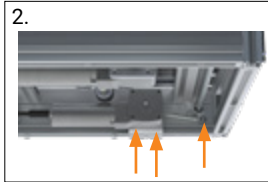

2.  
Remove the screw on the rod end and the fastening screws of the motor plate.

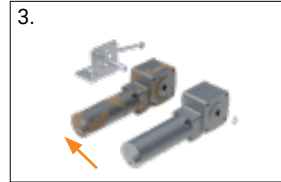

3.  
Remove the circlip, then remove and replace the motor.

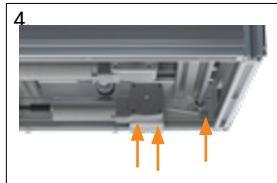

4.  
Reattach the screw on the rod end and the fastening screws on the motor plate.

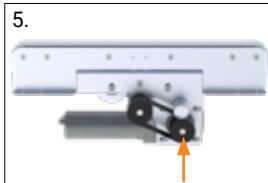

5.  
Reattach the bottom cover.

## 10. Components used

### 10.1 Lifting unit motor

	<p><b>Manufacturer:</b> SEW <b>Type:</b> Low-voltage drive WA03DCA63M, <b>Item number:</b> i = 48</p>
---	---

### 10.2 Timing belt motor

	<p><b>Manufacturer:</b> SEW <b>Type:</b> Low-voltage drive WA03DCA63L <b>Item number:</b> i = 48 up to 13 m/min: i = 27.5 up to 36 m/min: i = 16.5 up to 61 m/min:</p>
---	--

### 10.3 Roller conveyor zone sensor in the Transfer Unit 90° zone

	<p><b>Manufacturer:</b> Wenglor <b>Type:</b> P1KY102 <b>Item number:</b> 313262</p>
---	---

#### 10.4 Inductive sensor

- Sensor for upper and lower position of the Transfer Unit 90°

	<b>Manufacturer:</b> Wenglor <b>Type:</b> I08H001 <b>Item number:</b> 368392
---	--

#### 10.5 Timing belt

- Belt for transporting the products

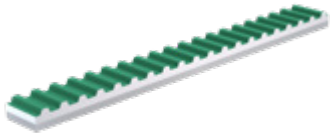
	<b>Manufacturer:</b> Optibelt <b>Type:</b> ALPHA LINEAR V AT5K6 - ST Polyurethane 92A white <b>Item number:</b> COL4101SNN
---	---

#### 10.6 RJ10 interface cable

- Optional for wiring (see chapters 6.4/6.6)

	<b>Manufacturer:</b> SEW <b>Type:</b> TAE 3M 368392 <b>Item number:</b> 1241502 <b>SEW number:</b> 8146993
--	--

#### 10.7 USM21A Interface Adapter incl. cable

- Optional for changing the parameters with the DCA Shell software

	<b>Manufacturer:</b> SEW <b>Type:</b> USM21A <b>Item number:</b> 193642 <b>SEW number:</b> 28231449
---	--

# 11. EU Declaration of Incorporation

(in accordance with 2006/42/EC from 09.06.2006, Annex VII, part B for the incorporation of partly completed machinery)

We, as the manufacturer of the partly completed machinery, hereby declare under our sole responsibility that for the machine specified below:

- the essential requirements of the harmonized directive 2006/42/EC listed below were applied and complied with
- the specific technical documentation was created in accordance with Annex VII, Part B
- this specific technical documentation will be transmitted in accordance with Annex VII, Part B, in response to a reasoned request, to the national authorities in printed form or electronically (pdf)

**Manufacturer:** Robotunits GmbH  
Dr. Walter Zumtobel Strasse 2  
6850 Dornbirn, AUSTRIA

**Product:**

**Harmonized regulation (directive):**  
2006/42/EC (09/06/2006) Applied and fulfilled essential requirements:  
1.1.2., 1.1.3., 1.1.5., 1.3.1., 1.3.2, 1.5.8, 1.5.9, 1.5.13  
2014/35/EU Low Voltage Directive  
2014/30/EU EMC Directive

**Authorized representative for the technical documentation:** Robotunits GmbH  
Dr. Walter Zumtobel Straße 2  
6850 Dornbirn, AUSTRIA

This partly completed machinery must not be put into service until the machine into which this partly completed machinery is to be incorporated has been declared in conformity with the regulations of the Machinery Directive 2006/42/EC.

**Signed for and on behalf of:** Robotunits GmbH

  
\_\_\_\_\_  
Christian Beer  
Managing Partner

Dornbirn, 29/05/2024

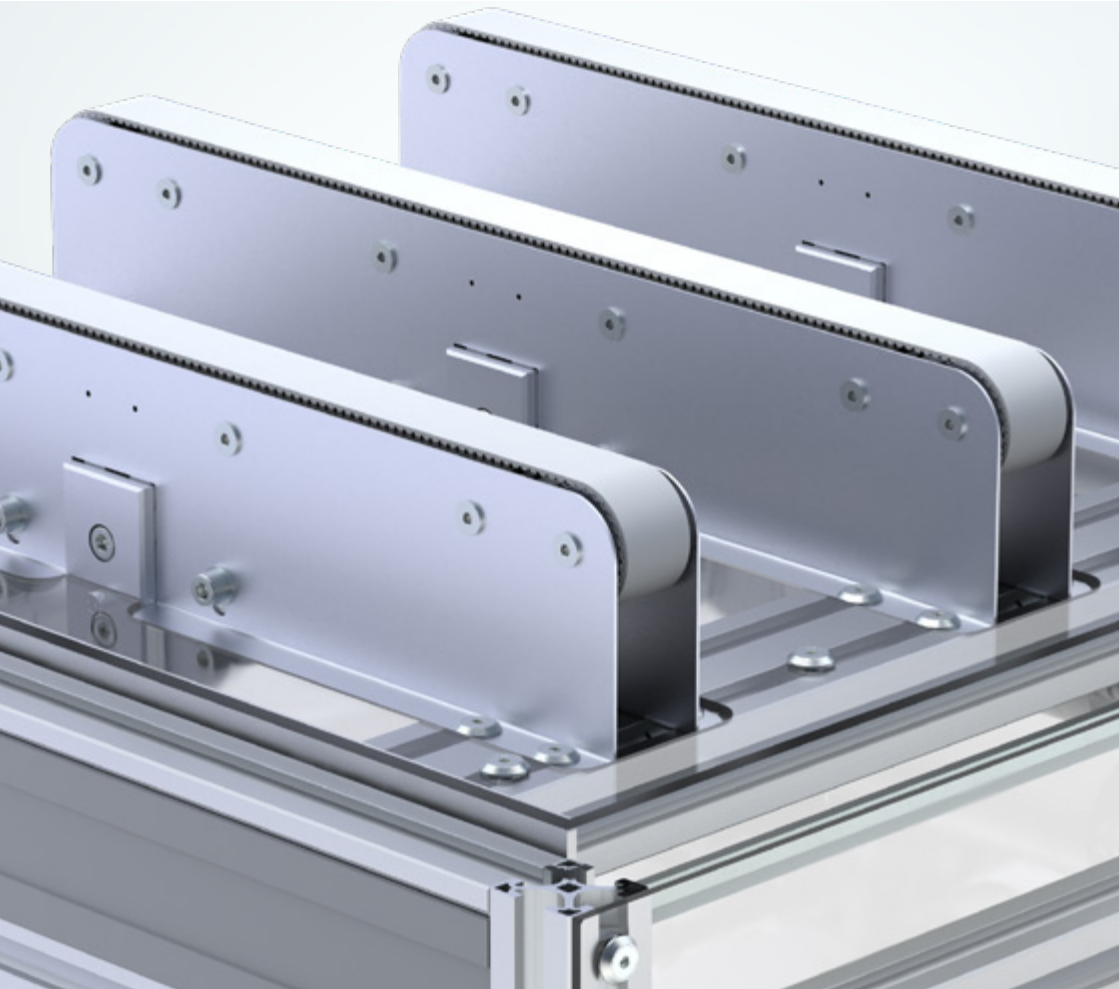

We reserve the right to alter technical specifications at any time.  
We assume no liability for typesetting and printing errors.

Austria - Germany - Switzerland - Italy - France - Spain - Czech Republic - USA - Australia

[www.robotunits.com](http://www.robotunits.com)