

Storage and Feeder Hopper Conveyors



➤ Ready for dispatch after
10
working days!

The Robotunits Storage and Feeder Hopper Conveyors:
ingeniously simple solutions from the
Robotunits Modular Automation System.

Storage and Feeder Hopper Conveyors

Based on C4N

With cleverly devised multifunctional attachments, the tried-and-tested Robotunits C4N Belt Conveyor can be transformed into a Storage Hopper or Feeder Hopper Conveyor with a wide range of possible applications: for example, as an ideal solution for feeding machines with bulk material or as a feeder into vibratory bowl feeders or spiral conveyors.

Facts

- variable size and equipment
- modular concept
- adjustable in height and inclination

Thanks to its modular design, the standard conveyor can be individually configured in terms of height, width and inclination. Using our Modular Automation System, we create cost-effective solutions for your application: from simple conveyors to plug-and-play solutions, with quick delivery and ready for use.

Benefits

- optimally adapted to the product and the application
- cost-effective and short delivery times
- quickly adjustable to the required infeed and outfeed heights

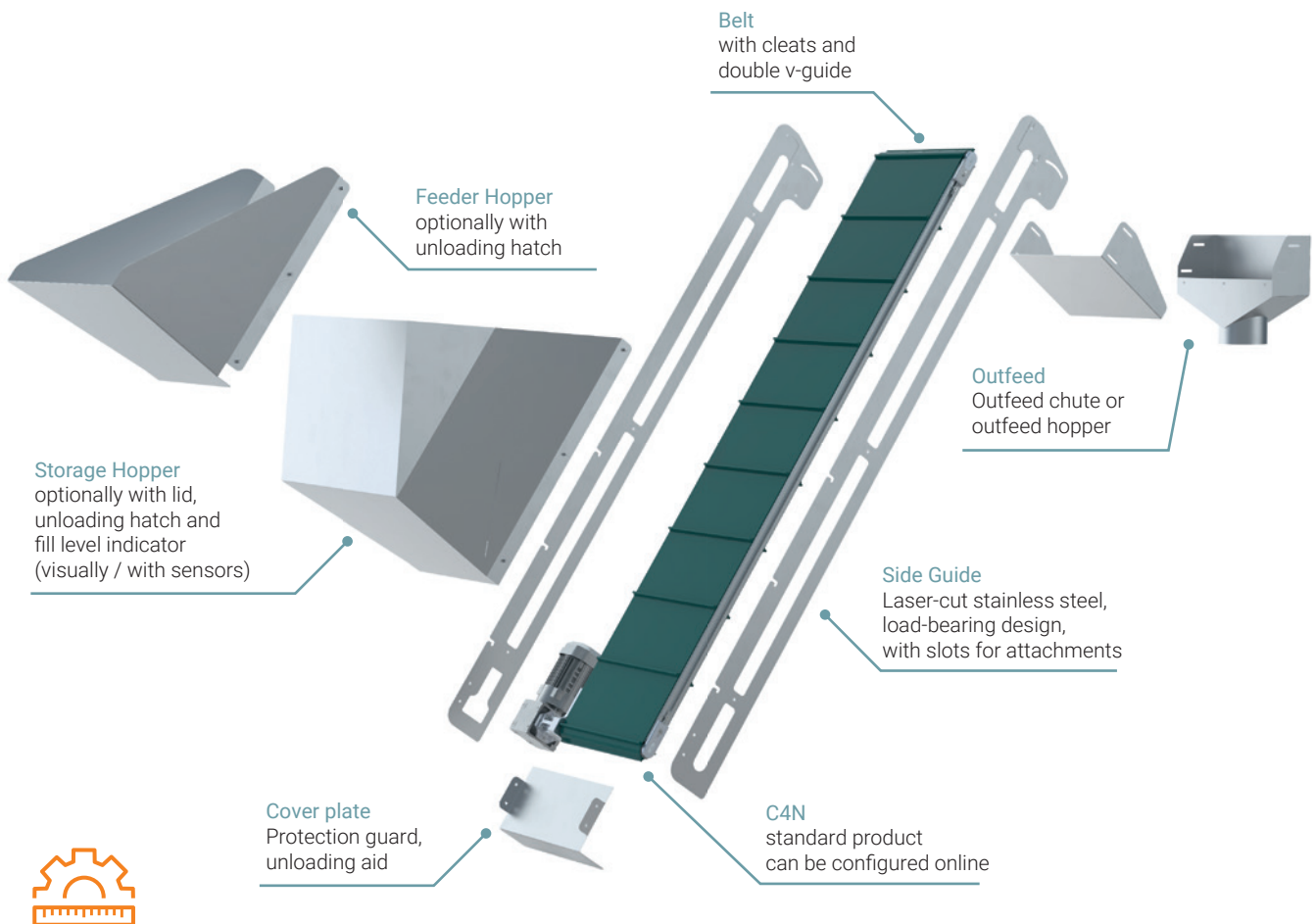

We test with your conveyed material!

Send us your material and we can test our conveyors directly with your products!

Technical data

Basis: Belt Conveyor size C4N
Conveyor frame width: 200 to 400 mm
Belt with transverse cleats, medium adhesive, abrasion-resistant
Cleit height: 4 to 30 mm
Double v-guide on the underside of the belt

Bulk material, solid and dimensionally stable parts
Inclination angle: 40 - 70°
Speed: according to C4N specification
Indexing operation possible
Speed Controller
Plug-and-play



Storage and Feeder Hopper Conveyors

Options

Storage Hopper Conveyor with the following equipment:

- Infeed: storage hopper with fill level indicator sensors
- Conveyor: cover hood made from polycarbonate
- Outfeed: outfeed hopper
- Stand: fixed with leveling bases



Example 1
further options possible

Feeder Hopper Conveyor with the following equipment:

- Infeed: hopper (metal sheets)
- Outfeed: outfeed chute
- Stand: adjustable in height and inclination; on swivel castors



Example 2
further options possible



Unloading hatch with sliding lock and visual fill level indicator



Storage Hopper with fill level indicator sensors



Outfeed chute, outfeed hopper, cover hood

Storage and Feeder Hopper Conveyors

Stand



Fixed with leveling bases



Fixed with swivel castors



Adjustable in height and inclination

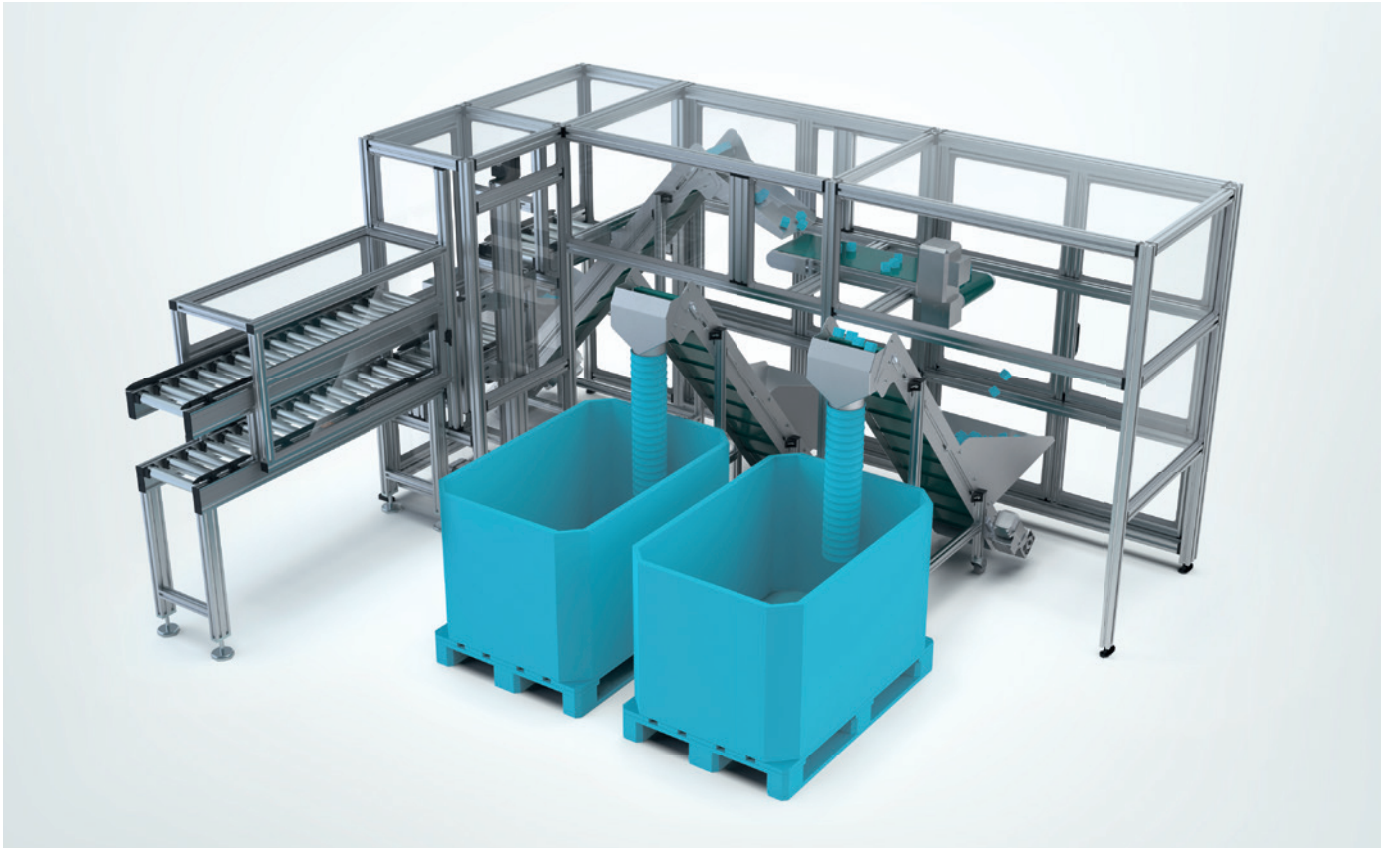

**Standardized application solutions
individually adapted to your needs**

The field-tested applications from the Robotunits Modular Automation System offer ingenious solutions for optimizing your production processes.



Discover applications
<https://robotunits.com/en/applications/>



Outstanding Quality



Uncompromising Service



Fastest Delivery Times