



**ROBOTUNITS®**

SYSTEMATICALLY. BETTER. TOGETHER.



# ***LINEAR MOTION UNIT***

Operating and assembly Instructions

# INDEX

<b>1. General</b>	<b>3</b>
1.1. System manufacturer	3
1.2. Purpose of the operating and assembly instructions	3
1.3. Site-pre conditions	3
1.4. Version	3
<b>2. Safety</b>	<b>4</b>
2.1. Safety guide lines	4
2.2. Avoiding potential misuse	4
<b>3. Transport &amp; assembly</b>	<b>5</b>
3.1. Handling of incomplete machinery	5
3.2. Transport material requirements	5
<b>4. Operating instructions</b>	<b>6</b>
4.1. Adjusting the belt tension	6
4.2. Adjusting the tension force & resonant frequency	6
4.3. Adjusting the carriage	7
<b>5. Maintenance &amp; repairs</b>	<b>9</b>
5.1. Personnel requirements	9
5.2. Maintenance schedule	9
5.3. Repair procedures	9
5.4. Changing the belt	9
<b>6. Mechanical design &amp; system</b>	<b>11</b>
6.1. Linear Motion Unit	11
6.2. Linear Motion System	12

# 1. GENERAL

## 1.1. SYSTEM MANUFACTURER

Robotunits Inc.  
8 Corporate Drive  
Cranbury, NJ 08512  
Tel. 732-438-0500  
www.robotunits.com

## 1.2. PURPOSE OF THE OPERATING AND ASSEMBLY INSTRUCTIONS

This document provides instructions for assembly linear motion units that are delivered without a drive/control system. As per the Machinery Directive 2006/42/EC, Art. 2g, these linear motion units are deemed to be an incomplete machine. For the official installation declaration, refer to the accompanying documents.

## 1.3. SITE-PRE CONDITIONS

Ensure the following conditions are met at the installation site:

- > Adequate load capacity to support the linear drive (refer to the technical data sheet for weight specifications)
- > Ensure flat surfaces at the flange positions
- > Holes ready for screw connections
- > Installation position (according to technical data sheet)
- > Where required (safety), install covers on drives and the movement area of the guide carriage
- > Use sensors or stops to limit movement, if equipped with sensors ensure proper values and connection types (details in the technical data sheet).

## 1.4. VERSION

Version	Type	Date
4	Operating / Installation instructions	2021-12-01



## 2. SAFETY

### 2.1. SAFETY GUIDE LINES

To ensure the safety of the operator and the smooth operation of the incomplete machine, only original machine parts should be used

### 2.2. AVOIDING POTENTIAL MISUSE MISUSE



The incomplete machine is not intended for use in environmental temperatures outside the range of - 20°C to +60°C. Ensure compliance with protection class IP54 regarding atmospheric moisture. Operating the incomplete machine in explosive atmospheres is strictly prohibited

### 3. TRANSPORT & ASSEMBLY

#### 3.1. HANDLING OF INCOMPLETE MACHINERY



Ensure that the incomplete machinery is secured to prevent tipping over during transport and storage. All movable parts, such as carriages, should be fixed securely in position.

We advise not to store the incomplete machine outdoors to protect it from environmental damage

#### 3.2. TRANSPORT MATERIAL REQUIREMENTS



Always consider the machine's center of gravity when lifting.



Avoid standing directly under the load when the machine is being lifted or transported

Ensure the use of robust and adequate packaging and transport materials to protect the machinery during transit.

## 4. OPERATING INSTRUCTIONS

### 4.1. ADJUSTING THE BELT TENSION

The belt tension must be re-adjusted after the first 1000 movements!

When adjusting, it's essential to ensure that both screws of the belt tensioning set are tightened uniformly, ensuring the belt is tensioned in parallel.

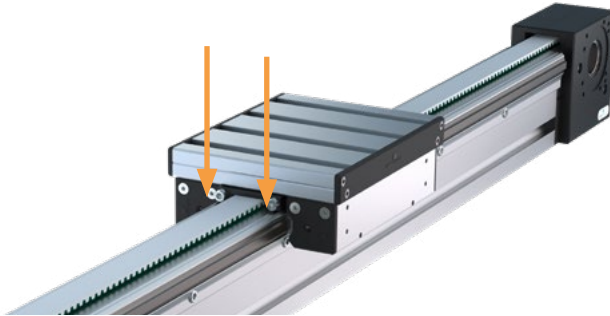

### 4.2. ADJUSTING THE TENSION FORCE & RESONANT FREQUENCY

The tension force depends on the belt's effective length, its width, the specific own weight, and the resonant frequency. Users can determine the tension force or resonant frequency with a tension meter.

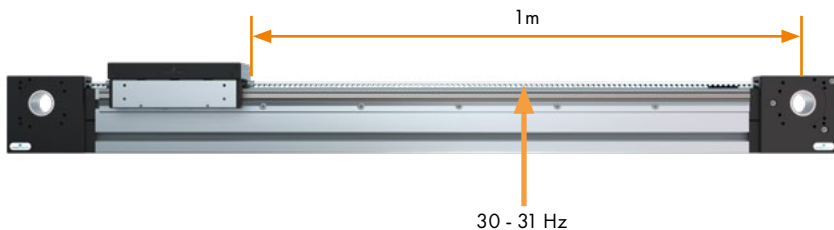

## 4. OPERATING INSTRUCTIONS

### 4.3. ADJUSTING THE CARRIAGE

Due to variations and different load types, the carriage play must be re-adjusted after the first 1000 movements.

**Attention:** The carriage can only be adjusted when the belt is removed from it.

#### **Procedure:**

4.3.1. Loosen the set screw to unlock the jam nut



4.3.2. Use an Allen key to align the eccentric roller with the guide rail without applying force



## 4. OPERATING INSTRUCTIONS

4.3.3. Take out any play between carriage and guide rail.

4.3.4. Secure the eccentric roller by tightening the jam nut with the corresponding wrench



4.3.5. Fasten the set screw to ensure jam nut remains secure

4.3.6. Move the carriage along its path. Ensure smooth movement while applying a force between 18-20 N

**Attention: Always perform these adjustments with the belt removed from carriage**

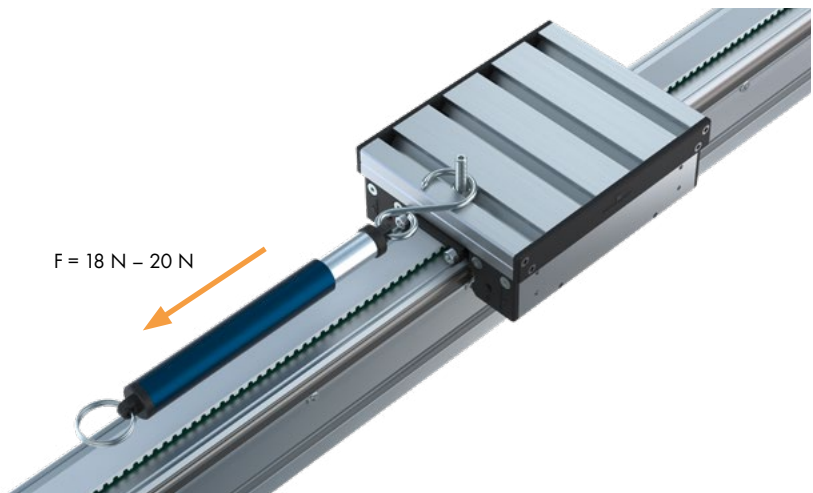

## 5. MAINTENANCE & REPAIRS

Consistent and proper machine maintenance ensures its reliable operation and longevity. Before performing any maintenance, always ensure the incomplete machine is disconnected from the power supply

### 5.1. PERSONNEL REQUIREMENTS

Maintenance should only be performed by qualified and authorized personnel

### 5.2. MAINTENANCE SCHEDULE

Service point / activity	Maintenance interval	Info
Belt tension	After 1000 operating cycles	Once
Slide play	After 1000 operating cycles	Once
Clean linear guide	Every 600 h	
ALubricate wiper unit	Every 600 h	Slideway oil DIN CGLP ISO VG68 (e. g. Mobil Vactra No. 2)
Check belt condition	Every 600 h	Visual inspection
Check machine for loosened screws	Every 2000 h	

### 5.3. REPAIR PROCEDURES

Repairs may only be carried out by Robotunits or by a service center authorized by Robotunits.

### 5.4. CHANGING THE BELT

5.4.1. Loosen the screws of the belt tensioning set:



## 5. MAINTENANCE & REPAIRS

5.4.2. Remove the belt tensioning set:



5.4.3. Loosen the fastening screws of one pulley:

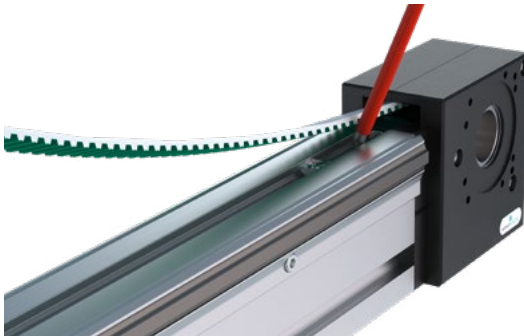

5.4.4. Pull out the belt:

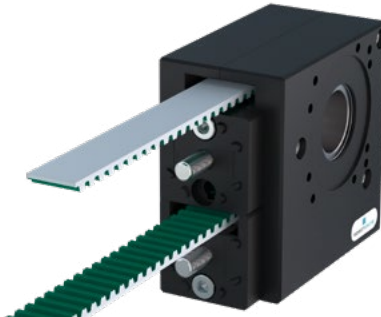

## 6. MECHANICAL DESIGN & SYSTEM

### 6.1. LINEAR MOTION UNIT

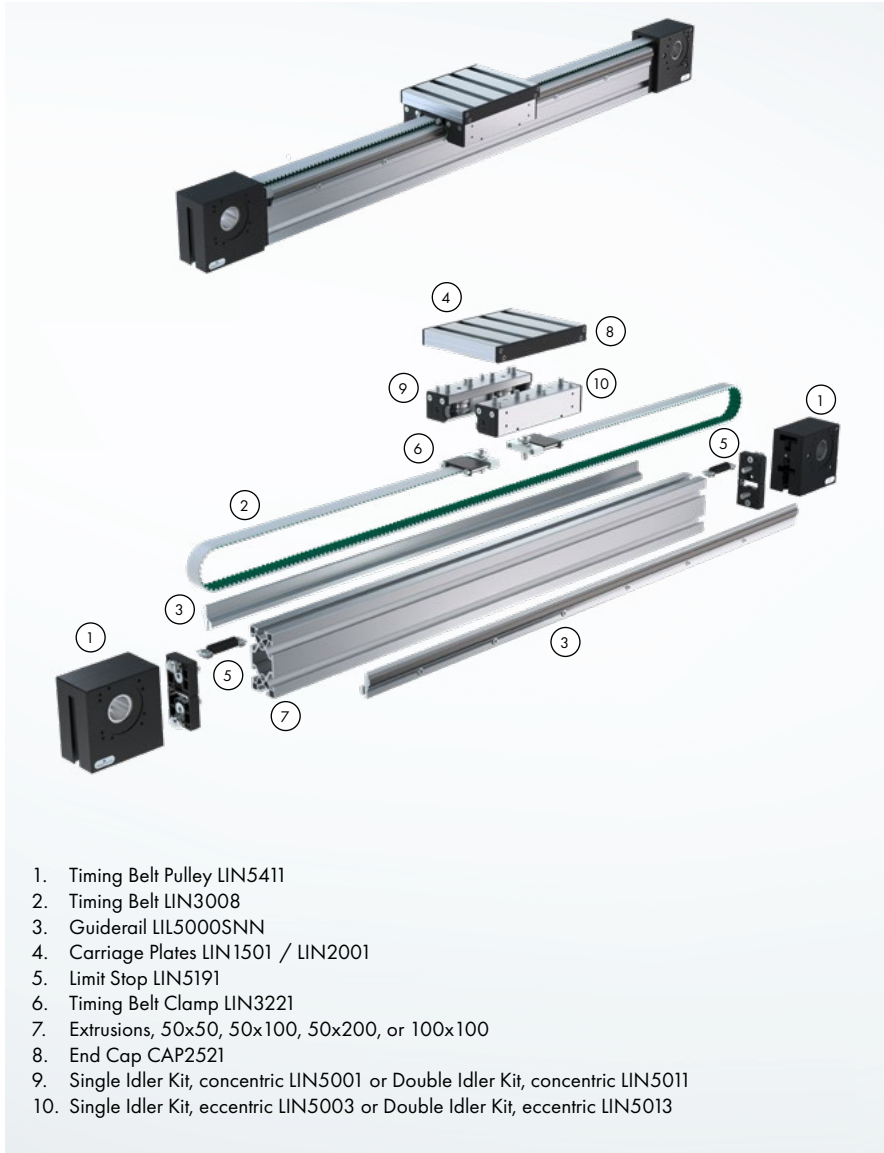

## 6. MECHANICAL DESIGN & SYSTEM

### 6.2. LINEAR MOTION SYSTEM

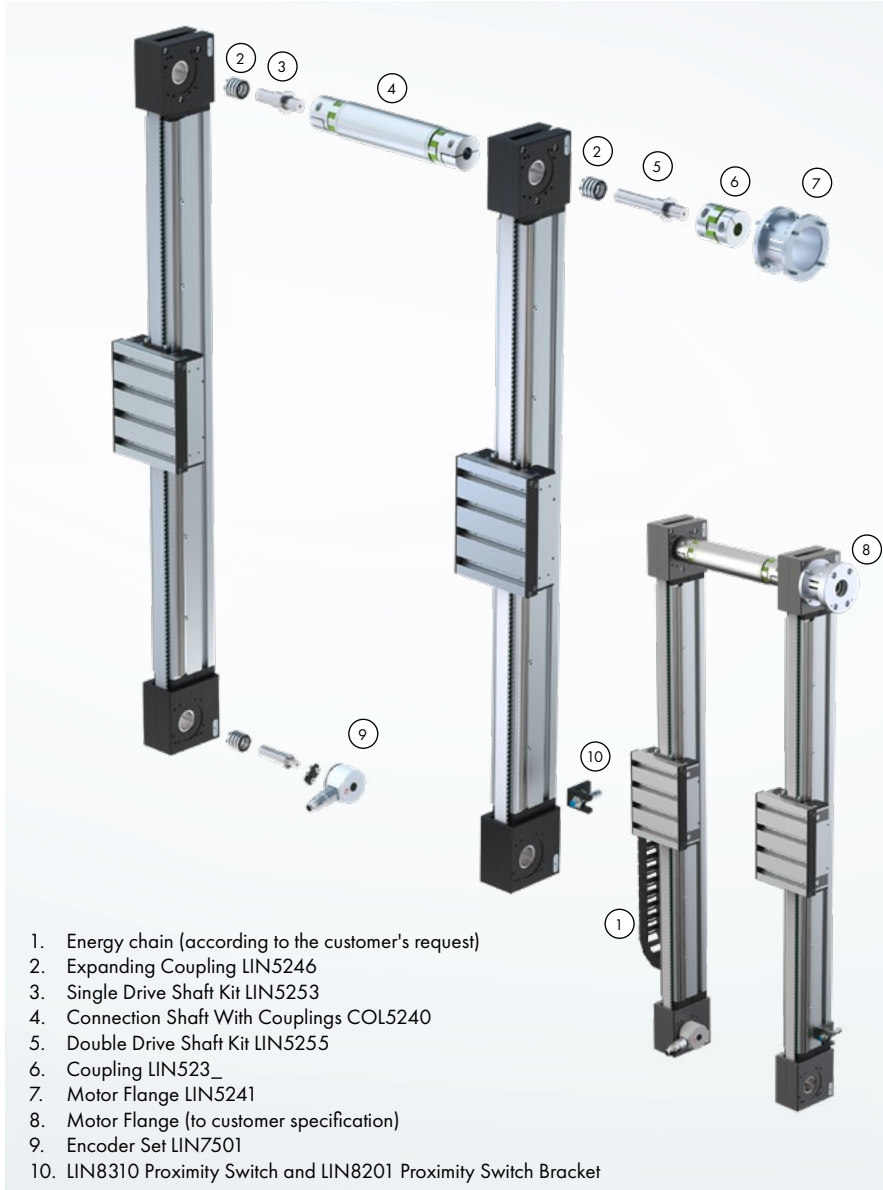

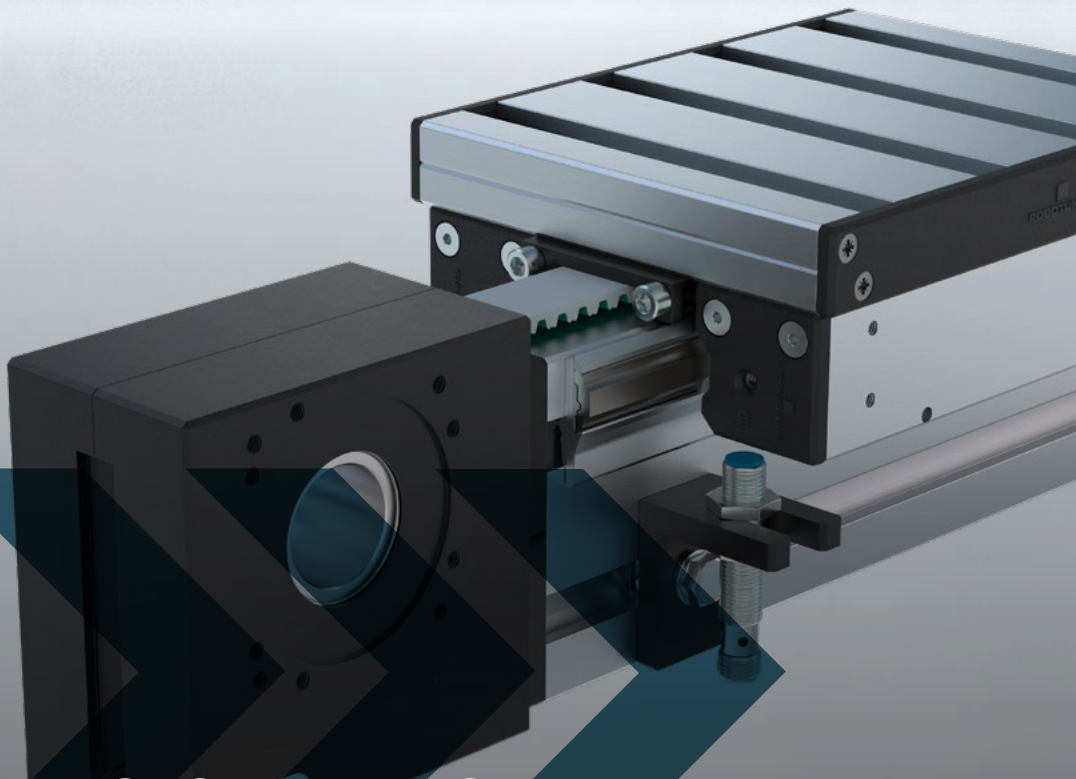

**SYSTEMATICALLY >>>>**  
**>>> BETTER TOGETHER**

We reserve the right to alter technical specifications without prior notice.  
We assume no liability for typing and printing errors.

USA • Austria • Germany • Switzerland • Italy • France • Spain • Czech Republic • Australia

[www.robotunits.com](http://www.robotunits.com)